

Z-VENT®

INSTALLATION AND MAINTENANCE INSTRUCTIONS

3" - 24" SINGLE AND DOUBLE WALL SPECIAL STAINLESS STEEL VENTING SYSTEM

FOR GAS BURNING APPLIANCES

CATEGORY I, II, III, & IV



UL1738 & ULC-S636

Read the following before installation of venting system.

- * Examine all components for possible shipping damage prior to installation. *
- * The vent system must be free to expand and contract. Check for unrestricted vent movement through walls, ceilings and roof penetrations. *
- * The vent system **must** be properly supported "**DURING ASSEMBLY**" vertically & horizontally as prescribed in this manual. Failure to support the components at the point of install will cause undue stress on the joints of the components and fittings thereby voiding warranty.
- * Proper joint assembly is essential for a safe installation. Follow these instructions exactly as written. Check the connection of all joints during and after completion of assembly for proper insertion depth and check gear clamps of single wall vents for proper torque. *
- * Different manufacturers have different joint systems and adhesives. Do Not Mix Pipe, Fittings or Joining methods from different manufacturers beyond the flue collar adaptor. *

WARNING! CONDENSATION WITH HIGH ACID CONTENT MAY BE PRODUCED DUE TO UNFORESEEN CONDITIONS. THE HEATING APPLIANCE AND VENTING SYSTEM SHOULD BE INSPECTED BY A LICENSED CONTRACTOR ON AN ANNUAL BASIS FOR POSSIBLE SIGNS OF DETERIORATION DUE TO RUSTING OR PIN HOLES. CONDENSATION WITH HIGH ACID CONTENT WITH PH LEVELS BELOW 2.5 MAY CAUSE LEAKAGE OF HARMFUL GASES WHICH CAN CAUSE NAUSEA, FAINTING OR DEATH. IF APPLIANCE PH LEVEL IS BELOW 2.5 OR DETERIORATION IS DETECTED, IMMEDIATELY CEASE USE OF THE HEATING SYSTEM AND CALL FURNACE / BOILER INSTALLER FOR REMEDIAL ACTION.

IMPORTANT: The qualified installing contractor must leave this instruction with the end-user along with a vent layout drawing of the install detailing the entire vent system including all enclosures, access doors, condensate drains etc. The installer shall instruct the end-user on how to check the condensate drains periodically and if required, how to fill with water.

WARNING!

A by-product of any fuel burning appliance is carbon monoxide, which is an invisible and odorless gas. Read, understand and follow all instructions and appropriate local codes when installing, using or maintaining any fuel burning appliance and vent system. Install carbon monoxide detector and alarms in accordance with local codes.

The information provided within is for informational purposes only. We have made every effort to ensure the accuracy of the provided information and assume no responsibility for any loss or damage due to errors or omissions or to the use or misuse of any information supplied. It is impossible to test all products under all conditions to which they might be subjected in the field. It is therefore the buyer and/or end users' responsibility to test all products under the conditions that duplicate the service conditions prior to installation. All improvements, all specifications are subject to change without prior notice. It is the buyer and/or end users' responsibility to review our complete Terms and Conditions of Sale located on our web sites at: www.novaflex.com | www.z-flex.com | www.flexmaster.com.

CANADA:
 FLEXMASTER CANADA LTD.
 452 ATTWELL DR.
 ETOBICOKE, ONTARIO
 M9W 5C3
 (416) 679-0045

U.S.A.:
 Z-FLEX® US, INC.
 20 COMMERCE PARK, NORTH
 BEDFORD, N.H.
 03110-6911
 1(800) 654-5600

Visit our web site at www.z-flex.com

Table of Contents

<u>Contents</u>	<u>Page no.</u>
Hazard Definitions.....	2
Contaminants Notice.....	3
Observations to Note.....	3
Minimum Clearances to Vent Termination.....	4
Joint Procedure.....	5-7
Clearances to Combustible Materials.....	7
Horizontal / Side Wall Venting Installation.....	8-10
How to Cut Pipe - Single Wall Only.....	10-11
Single Wall Adjustable.....	11-12
Double Wall Adjustable.....	12-13
Condensate Tube / Drain Tee Installation.....	14
Support Systems.....	14-15
Vertical Venting Installation.....	15-16
Installing Firestop Spacer / Support.....	16-18
Installing Roof Jack Support System.....	19-20
Installing Vent Pipe Through Roof Jack Support System.....	20
Installing Vent Pipe Into an Existing Masonry Chimney.....	21
Special fittings.....	21-23
Typical Vertical Vent Illustrations & Associated Supports.....	22-23
Z-Vent® Smoothcore® Installation.....	24-27
Warranty.....	28

Hazard Definitions

The following terms are used throughout this Installation Guide to bring attention to potential hazards of varying risk levels or to important information concerning the product and / or its use.

DANGER!

Indicates the presence of a hazardous situation which, if ignored, will result in death, serious injury or substantial property damage.

WARNING!

Indicates a potentially hazardous situation which, if ignored, can result in death, serious injury or substantial property damage.

CAUTION!

Indicates a potentially hazardous situation which, if ignored, may result in minor injury or property damage.

NOTICE

Indicates special instructions on installation, operation or maintenance, which are important to equipment but not related to personal injury hazards.

Contaminants Notice

It is understood that all appliances requiring inside combustion air must have sufficient supply of the air for proper combustion of the fuel air mixture within the appliance. What may not be understood is this supply of air shall be free of corrosive contaminants. Air mixture containing corrosive contaminants when under fire through the combustion process of the appliance produces exhaust gases containing these corrosive contaminants. These contaminants are prevalent in the condensate of these gases throughout the vent system and will eventually damage the vent material. Refer to Table 1 for listing of products.

The supply air to the heating appliance shall be free of any contaminants. Heating appliances installed in areas where the supply air is contaminated shall have clean combustion air piped directly to the unit.

PRODUCTS THAT WILL CONTAMINATE THE COMBUSTION AIR SUPPLY IN THE MECHANICAL ROOM	
Salts - Sodium Chloride used in water softeners	Adhesives, cements, glues used to fasten building products
Dirty air due to renovation / construction	Solvents containing Hydrochloric acid / Muriatic acid
Chlorine based swimming pool chemicals	Chlorinated waxes and/or cleaners
Chlorine type bleaches, cleaning solvents, laundry detergents	Aerosol sprays containing Chlorofluorocarbons (CFC's)
Fabric softeners used in clothes dryers	Paint & varnish and remover solvents
Permanent wave hair product solutions	Refrigerant leaks

Table 1: Corrosive Contaminants - List is subject to change without notice.

WARNING!

With the above contaminants present, failure to remove these contaminants or to pipe combustion air directly to the heating appliance can eventually lead to the deterioration of the venting material by way of the contaminated condensate, resulting in severe personal injury, death or substantial property damage.

SPECIAL STAINLESS STEEL VENTING

For use with Category I, II, III, & IV gas burning appliances

Observations to Note

Contact Local Building or Fire Officials about Restrictions and Installation Inspections in your area as well as National codes: USA - National Fuel Gas Code ANSI-Z223.1/NFPA 54, CANADA - CAN/CSA-B149.1 Natural Gas and Propane Installation Code. Please refer to appliance manufacturers' instructions to determine proper sizing and connection of venting system to appliance, including maximum horizontal length, maximum height, and installation clearances (air spaces). The proper operation of the vent system and appliance requires parts specified by Z-FLEX® with no deletions or substitutions.

In order to validate a warranty installation Z-FLEX® recommends that a professional with Special Gas Venting experience or a certified Gas Ticket professional MUST perform the installation.

These instructions are intended as a guide to assist a professional installer.

When the vent system is installed, the following should be observed:

1. A venting system that exits the structure through a sidewall or the like, shall terminate not less than 12 inches (254 mm) above the ground or normal snowline. (See Minimum Clearance to Vent Termination Illustration 1).
2. The termination of a system shall be located above the snow line in geographical areas where snow accumulates. The termination area should be kept clear of snow and ice at all times.
3. The vent shall not terminate less than 7 ft. (2.13 m) above a paved sidewalk or driveway.
4. The termination shall be 6 ft. (1.8 m) or more from the combustion air intake of any appliance.
5. The system shall terminate more than 3 ft. (0.91 m) from any other building opening, gas utility meter, service regulator or like.
6. TO LIMIT CONDENSATION, FREEZING & PROTECT AGAINST MECHANICAL FAILURE: When installing 5 ft. (1.5 m) or more of single wall vent in an unheated space (crawl spaces, building exteriors above the roof line) it is recommended to convert to double wall vent. Use firestop spacers/supports at any ceilings/floors penetrations and ensure no insulation is in the clearance to combustible (air space) surrounding vent - See Table 2. Enclose any exterior single wall vent systems below the roof line or use double wall vent. Install any condensate drain(s) at least 2 ft. in the interior of the heated building to avoid condensate freezing. Seal circumference of ZV-Clamp bands mounted exterior to building with silicone, Dow 732 (grey) is recommended.

WARNING!

Running vent exterior to a building may present a freeze concern, especially when venting condensing appliances. To address this concern vent runs shall be; short as possible, horizontal vent pitch should be $\frac{1}{4}$ in. per 1 ft. up to termination, elbows shall be reduced, exterior tees shall be eliminated, drains shall be located at least 2 ft. inside a heated space, double wall vent shall be utilized for entire vent run (interior & exterior).

With above in mind its best practice to discuss exterior vent runs with appliance manufacturer and local code official or authority having jurisdiction before proceeding as experience and codes may restrict exterior vent runs or mandate additional requirements.

MINIMUM CLEARANCE TO VENT TERMINATION

Sidewall Clearances - Category III & IV Appliances

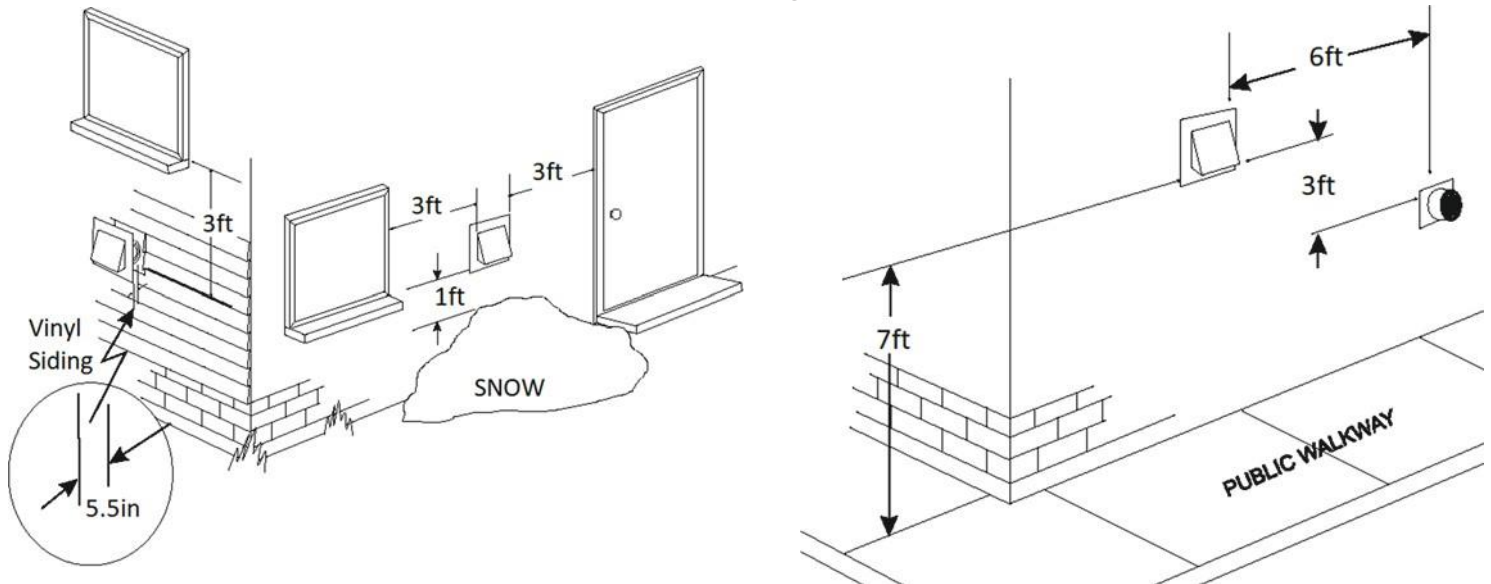
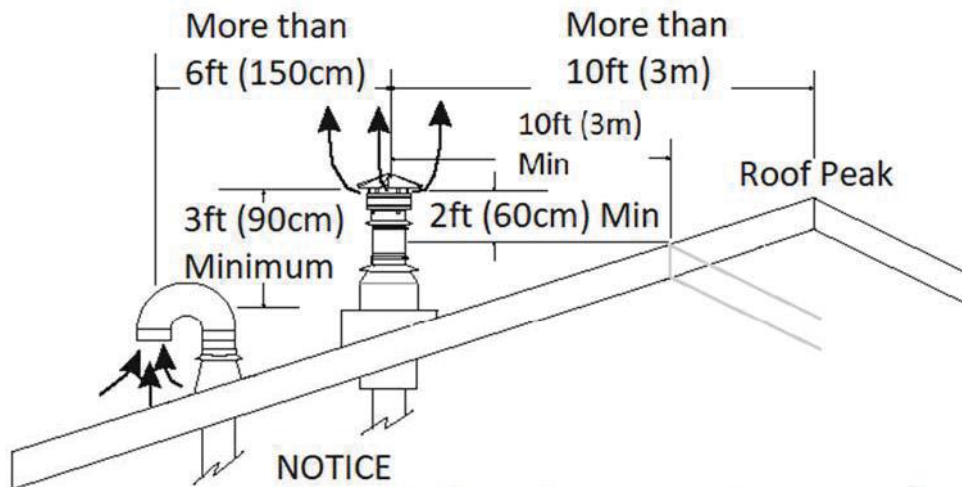

Illustration 1

Vertical Clearances



NOTICE

No height above the roof peak is required for the roof termination when the lateral distance from the roof peak is more than 10ft (3m)

Illustration 2

NOTICE

The vent terminations of some Listed appliances may be installed at lesser clearances when specified in the appliance installation instructions and in compliance with NFPA 54 or CSA B149.

NOTICE

- A. The Z-FLEX® SPECIAL STAINLESS VENT SYSTEM is for use only with appliances having a positive vent pressure of 8" of water column or less.
- B. Except for installation in one and two family dwellings, a venting system that extends through any zone above that on which the connected appliance is located shall be provided with an enclosure having a fire resistance rating equal to or greater than that of the floor or roof assemblies through which it passes
- C. Do not wrap the pipe with insulation or cladding or place any type of insulation within the required air spaces surrounding the venting system.
- D. A termination must be used on all installations to assure proper operation and to prevent debris from entering the venting system. Category I appliances must use a Rain Cap with WIND BAND; part numbers 2SV(S,D)RCX___ to prevent debris and rain from entering the venting system.
- E. Vertical runs must be supported; at base of vertical run, at single wall adjustable pipe joint outlet, at every ceiling/floor and at roof if appropriate.
For vertical runs a support is required every 16 ft. (4.88m) or less of vertical height.
Horizontal runs must be supported; within 1 ft. of appliance adaptor, at floor if appropriate and each elbow.
For horizontal runs a support is required every 48" (every 60" for Double Wall with ZV-CLAMP) or less of horizontal length.
- F. It is recommended that *vertical* and *horizontal drain tees* with at least 3 inch p-traps be installed on long vent systems in order to eliminate the system of condensate as quickly as possible.
- G. It is recommended to align and orient weld seams upwards towards ceiling in any horizontal vent runs.

JOINT PROCEDURE

The female end of each vent component incorporates a self-sealing gasket. Examine all components for damage to ensure that gasket integrity has remained intact during shipping.

WARNING! Joint connections not meeting the full insertion can leak causing severe personal injury, death or substantial property damage.

SINGLE WALL: (See Images 1, 2 & 3)

1. Apply lubricant p/n 2LUBE to gasket, insert male end into female section while keeping pipes parallel use a twisting motion and push together until indent on male end of pipe aligns up with end of female section or at least inserts:
 - i) 1.75 inches for diameters up to 12 inch.
 - ii) 2.75 inches for diameters 14 inch thru 24 inch.**PIPE JOINT NOT MEETING THE MINIMUM ABOVE PARAMETER IS NOT FULLY SEATED AND IS THEREFORE AN UNACCEPTABLE CONNECTION.**
2. Tighten gear clamp to a **minimum** torque of 40 in/lbs. and a **maximum** of 50 in/lbs. (**Gear clamps are on diameters up to 12 inch only not required on diameters 14 inch thru 24 inch**).

WARNING! Over tightening the gear clamp can cause the seal to fail. DO NOT use power tools when tightening gear clamps.

DANGER! Fasteners (screws, rivets, etc.) must not penetrate the components of the single wall system either when joining pipes and fittings or using support straps. Drilling holes in the components is not permitted.

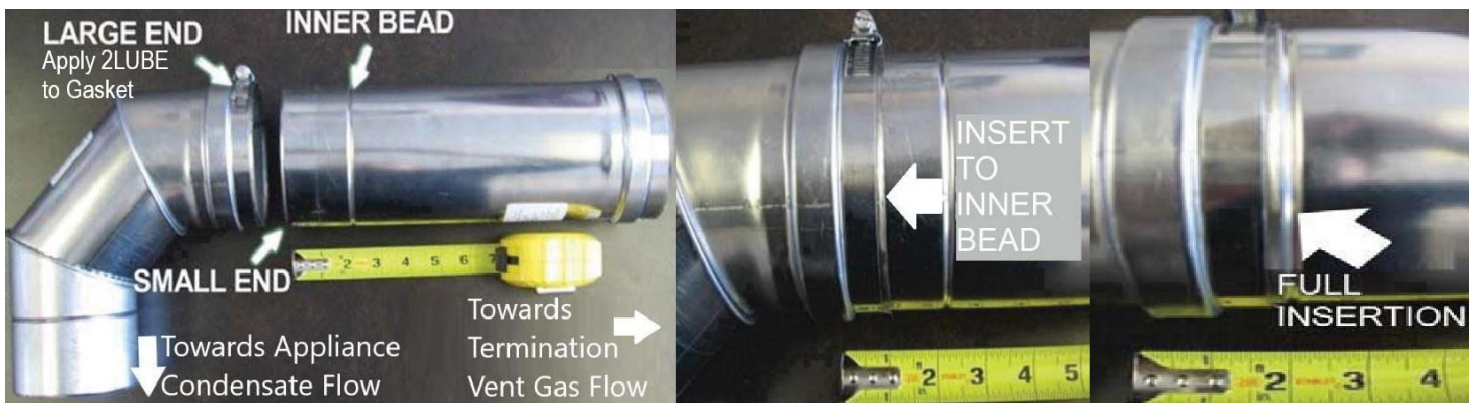

Image 1

Image 2

Image 3

DOUBLE WALL:

NOTICE

Proper pipe orientation is essential to achieve effective condensate flow. In most cases the use of an appliance specific **flue collar adaptor** is required to connect directly to the appliance. This adaptor will configure the vent orientation with the gasket end of pipe and fittings towards termination.

Also:

Some flue collars may require the use of high temperature silicone sealant to make a positive pressure gas tight seal.

DOUBLE WALL SNAP-LOCK:

1. Apply lubricant p/n 2LUBE to gasket, align pipes keeping them parallel use a twisting motion and push together until the snap-lock engages. (See Images 4, 5 & 6).

IMAGES BELOW SHOW DOUBLE WALL SNAP-LOCK PIPE CONNECTION

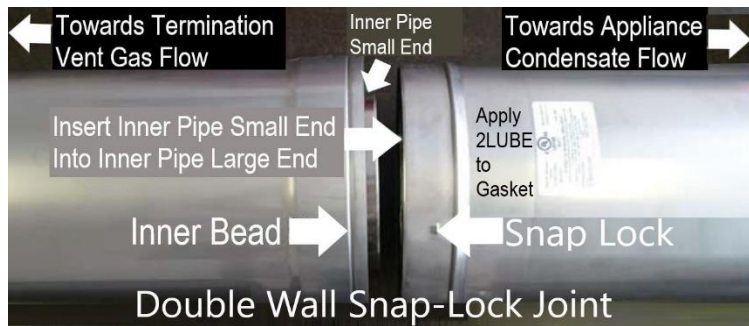

Image 4



Image 5

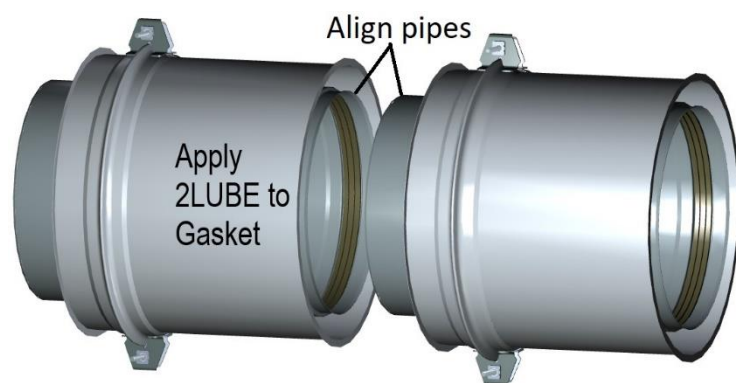

Image 6

DOUBLE WALL ZV-CLAMP:

1. Apply lubricant p/n 2LUBE to gasket, align pipes keeping them parallel use a twisting motion and push together until flanges on outer mating pipe touch, install ZV-Clamp over mating flanges and tighten ZV-Clamp bolts to 30 in/lbs. (See Images 7, 8 & 9).

IMAGES BELOW SHOW DOUBLE WALL ZV-CLAMP PIPE CONNECTION



Double Wall ZV-Clamp Joint

Image 7

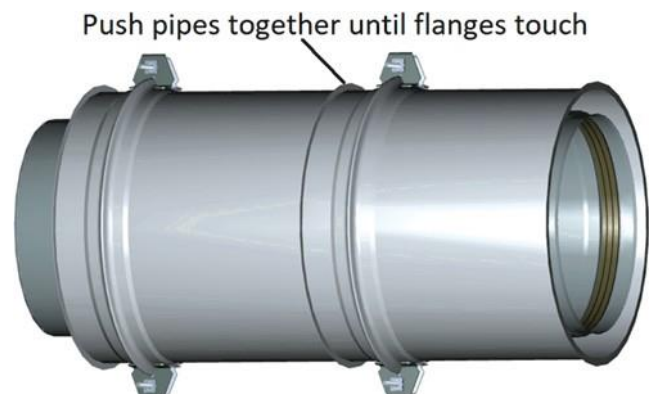

Double Wall ZV-Clamp Joint

Image 8

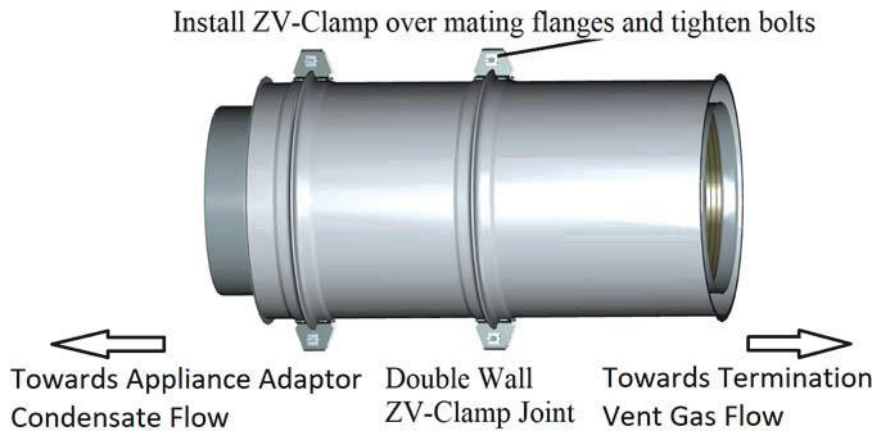

Image 9

MINIMUM AIR SPACE CLEARANCE TO COMBUSTIBLE MATERIALS AND BUILDING INSULATION					
VENT DIAMETER	MAXIMUM RATED VENT GAS TEMPERATURE	ENCLOSED		UNENCLOSED	
		HORIZONTAL	VERTICAL	HORIZONTAL	VERTICAL
UP TO 12"	550°F (288°C)	NON- COMBUSTIBLE MATERIAL	6" (150mm)	SINGLE WALL: 3" (75mm)	
	DOUBLE WALL: 2" (50mm)				
	480°F (249°C)	8" (200mm)	4" (100mm)	1" (25mm)	
14" TO 24"	480°F (249°C)	NON-COMBUSTIBLE MATERIAL			3" (75mm)
	300°F (149°C)	SINGLE WALL: NON-COMBUSTIBLE MATERIAL		1" (25mm)	
		DOUBLE WALL: 8" (200mm)	DOUBLE WALL: 4" (100mm)		

Non-Combustible Material is defined as material that is not capable of being ignited or burned, such material consisting entirely of, or a combination of, steel, iron, brick, tile, concrete, slate, glass, plaster (Source: NFPA-54 / ANSI 2223.1-1999)

Table 2: Clearance to Combustible Materials

NOTICE For double wall clearance is measured from the outer surface (double wall) of vent section.

HORIZONTAL / SIDE WALL VENTING INSTALLATION - CATEGORY III & IV APPLIANCES

(See Illustrations 1 & 3 and Images 10 & 11 or 12 & 13 for Double Wall ZV-Clamp)

1. Prior to beginning the installation, loosely assemble all parts required to make sure **all** parts are present.
2. Review the venting requirements section in the appliance manufacturer's installation & operating manual to determine the vent system configuration.
3. Select and apply the appliance adaptor to the flue outlet collar of the appliance.
4. Observing the sidewall vent termination rules on pages 3 & 4 and/or local building codes. Select the point of wall penetration where the minimum 1/4 inch per foot of slope (6.4 mm per 305 mm) can be maintained.
 - i. On a non-combustible wall, the pipe may be mortared in directly without using a wall thimble.
 - ii. A *wall thimble* is required if terminating through a combustible wall.
 - iii. A framed opening is required to insert the wall thimble halves and included adjustable pipe of Double Wall ZV-Clamp Wall Thimble see Table 3 or 4 for part I.D. and associated opening. The thimble is adjustable for different wall thicknesses consult Table 3 or 4 for appropriate part ID.

Wall Thimble Part ID		Single Wall or Double Wall-Snap (Inner/Outer) Diameter	Outer Single Wall or Double Wall to Thimble Clearance	Thimble to Combustible Clearance	Combustible Wall Inside Opening MINIMUM	Thimble Outer Plate Dimensions	Maximum Vent Gas Temperature
4"-7" Wall	7"-13" Wall						
2SVWT03	2SVWTM03	3"	1"	0"	5" x 5"	8" x 8"	480°F
2SVWT04	2SVWTM04	4"	1"	0"	6" x 6"	9" x 9"	480°F
2SVWT05	2SVWTM05	5" or 3"/5"	1"	0"	7" x 7"	10" x 10"	480°F
2SVWT064DW	2SVWTM064DW	4"/6"	1"	0"	8" x 8"	11" x 11"	480°F
2SVWT075DW	2SVWTM075DW	5"/7"	1"	0"	9" x 9"	12" x 12"	480°F
2SVWT06	2SVWTM06	6"	3"	0"	12" x 12"	15" x 15"	550°F
2SVWT07	2SVWTM07	7"	3"	0"	13" x 13"	16" x 16"	550°F
2SVWT08	2SVWTM08	8" or 6"/8"	3"	0"	14" x 14"	17" x 17"	550°F
2SVWT09	2SVWTM09	9" or 7"/9"	3"	0"	15" x 15"	18" x 18"	550°F
2SVWT10	2SVWTM10	10" or 8"/10"	3"	0"	16" x 16"	19" x 19"	550°F
2SVWT11	2SVWTM11	9"/11"	3"	0"	17" x 17"	20" x 20"	550°F
2SVWT12	2SVWTM12	12" or 10"/12"	3"	0"	18" x 18"	21" x 21"	550°F
2SVWT14	2SVWTM14	14" * or 12"/14"	3"	0"	20" x 20" *	23" x 23"	550°F 12"/14" Double Wall, * 300°F or Non-Combustible Material 14" Single Wall
2SVWT16	2SVWTM16	16" or 14"/16"	3"	0"	22" x 22" *	25" x 25"	* 300°F or Non-Combustible Material
2SVWT18	2SVWTM18	18" or 16"/18"	3"	0"	24" x 24" *	27" x 27"	* 300°F or Non-Combustible Material
2SVWT20	2SVWTM20	20" or 18"/20"	3"	0"	26" x 26" *	29" x 29"	* 300°F or Non-Combustible Material
2SVWT22	2SVWTM22	22" or 20"/22"	3"	0"	28" x 28" *	31" x 31"	* 300°F or Non-Combustible Material
2SVWT24	2SVWTM24	24" or 22"/24"	3"	0"	30" x 30" *	33" x 33"	* 300°F or Non-Combustible Material
2SVWT26	2SVWTM26	24"/26"	3"	0"	32" x 32" *	35" x 35"	* 300°F or Non-Combustible Material

Table 3: Single Wall & Double Wall Snap Wall Thimbles

Wall Thimble Part ID		Double Wall ZV-Clamp (Inner/Outer) Diameter (Nominal)	Outer Double Wall to Thimble Clearance	Thimble to Combustible Clearance	Combustible Wall Inside Opening MINIMUM	Thimble Outer Plate Dimensions	Maximum Vent Gas Temperature	Double Wall Adjustable Vent Overall Length	Double Wall Adjustable Vent Min. Effective Length	Double Wall Adjustable Vent Max. Effective Length	Double Wall Adjustable Vent Overall Length	Double Wall Adjustable Vent Min. Effective Length	Double Wall Adjustable Vent Max. Effective Length
4"-7" Wall	7"-13" Wall							2SVDWT_V			2SVDWTM_V		
2SVDWT06V	2SVDWTM06V	6"/8"	2"	0"	12" x 12"	15" x 15"	550°F	17.75	12.75	15.75	25.75	17.75	23.75
2SVDWT07V	2SVDWTM07V	7"/9"	2"	0"	13" x 13"	16" x 16"	550°F	17.75	12.75	15.75	25.75	17.75	23.75
2SVDWT08V	2SVDWTM08V	8"/10"	2"	0"	14" x 14"	17" x 17"	550°F	17.75	12.75	15.75	25.75	17.75	23.75
2SVDWT09V	2SVDWTM09V	9"/11"	2"	0"	15" x 15"	18" x 18"	550°F	17.75	12.75	15.75	25.75	17.75	23.75
2SVDWT10V	2SVDWTM10V	10"/12"	2"	0"	16" x 16"	19" x 19"	550°F	17.75	12.75	15.75	25.75	17.75	23.75
2SVDWT12V	2SVDWTM12V	12"/14"	2"	0"	18" x 18"	21" x 21"	550°F	17.75	12.75	15.75	25.75	17.75	23.75
2SVDWT14V	2SVDWTM14V	14"/16"	2"	0"	20" x 20" *	23" x 23"	* 300°F or Non-Combustible Material	17.75	11.75	14.75	25.75	16.75	22.75
2SVDWT16V	2SVDWTM16V	16"/18"	2"	0"	22" x 22" *	25" x 25"	* 300°F or Non-Combustible Material	17.75	11.75	14.75	25.75	16.75	22.75
2SVDWT18V	2SVDWTM18V	18"/20"	2"	0"	24" x 24" *	27" x 27"	* 300°F or Non-Combustible Material	17.75	11.75	14.75	25.75	16.75	22.75
2SVDWT20V	2SVDWTM20V	20"/22"	2"	0"	26" x 26" *	29" x 29"	* 300°F or Non-Combustible Material	17.75	11.75	14.75	25.75	16.75	22.75
2SVDWT22V	2SVDWTM22V	22"/24"	2"	0"	28" x 28" *	31" x 31"	* 300°F or Non-Combustible Material	17.75	11.75	14.75	25.75	16.75	22.75
2SVDWT24V	2SVDWTM24V	24"/26"	2"	0"	30" x 30" *	33" x 33"	* 300°F or Non-Combustible Material	17.75	11.75	14.75	25.75	16.75	22.75

Table 4: Double Wall ZV-Clamp Wall Thimbles

WARNING!

Review appliance manufacturer's instructions and verify above clearances in Table 3 or 4 for Wall Thimble is appropriate as it may be necessary to increase Combustible Wall Inside Opening MINIMUM for additional clearance.

- iv. Install wall thimble halves into wall; note inside wall plate may have tabs for gear clamp and may have ventilation holes / openings. Caulk around outside edge of plates as necessary and fasten to wall using field supplied caulk and hardware. DO NOT caulk ventilation openings on inside wall plate.
 - v. The termination shall be installed no less than 5-1/2 in. from a *combustible* exterior sidewall (See pages 3 & 4 for Sidewall Clearances).
 - vi. The vent pipe must be sealed with field supplied sealant at wall thimble as per code regarding continuous vapor barrier.
5. Continue connecting the required lengths of pipe and fittings starting from the appliance adaptor throughout the system making certain to follow the instructions in this guide with respect to i) Joint Procedure, ii) Slope iii) Supports iv) Clearances, v) Drain Traps and vi) Side Wall Termination.
 6. Installing the sidewall termination is achieved from installing pipe from outside through the wall thimble to the inside. Perform all joint connections per Images 1-9 using **JOINT PROCEDURE** as described on pages 5 - 7.
 - i. Connect the termination to the required length of pipe or included adjustable pipe of Double Wall ZV-Clamp wall thimble.

- ii. Insert the small end of the pipe or adjustable pipe of Double Wall ZV-Clamp wall thimble through the wall thimble from outside. (Note: The "UP" arrow on the label of the termination for proper orientation)
- iii. Install a gear clamp through tabs and around the pipe on the inside of wall to within ¼ inch of wall plate to secure the pipe in position so that the system cannot be moved in or out of wall (See Images 10 & 11 or 12 & 13 for Double Wall ZV-Clamp). This applies to both combustible and non-combustible walls.

Single Wall Thimble - Pipe & Termination Shown

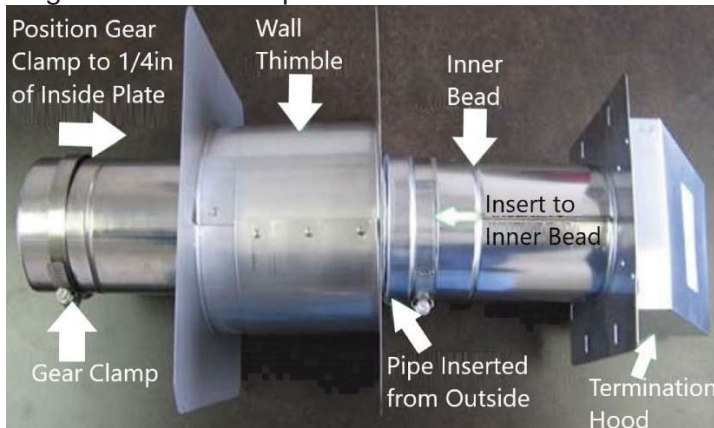

Image 10

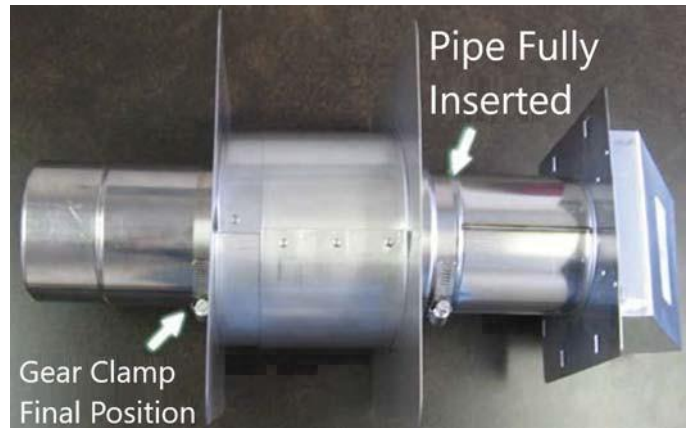

Image 11

Double Wall ZV-Clamp Thimble with Included Adjustable Pipe

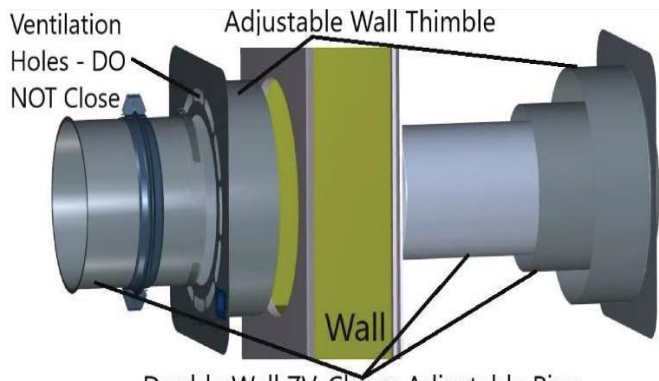

Image 12

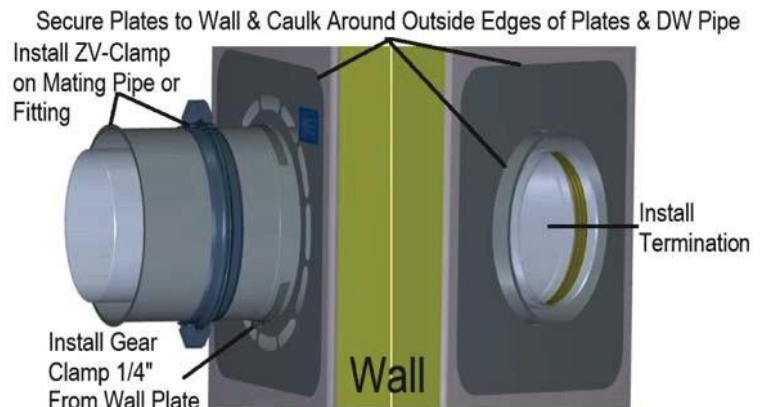

Image 13

7. Horizontal runs must be supported; within 1 ft. of appliance adaptor with Wall Support 2SVSWS__, at floor if appropriate with Floor Base Support 2SVSFBS__, and at every elbow with Wall Support 2SVSWS__ or loose stainless steel strapping, see Illustration 3. Maintain clearance to combustibles as per Table 2 on page 7.

For horizontal runs a support is required every 48" (every 60" for Double Wall with ZV-CLAMP) or less of horizontal length.

8. The horizontal distance of the system from the appliance flue collar to the outside of the horizontal termination shall not be greater than that specified in the appliance manufacturer's installation instructions.

Vent Pipe Slope

NOTICE All horizontally installed portions of a vent system shall have a slope (upwards) not less than ¼ in. (6.4 mm) every 12 in. (305 mm) to prevent collection of condensate at any location in the vent system. This condensate shall be directed to a condensate drain installed within the system.

HOW TO CUT PIPE - FOR SINGLE WALL ONLY

The pipe may be cut to length on the non-expanded end using aviation snips or a hacksaw with a 24 tpi blade. Make certain to keep the cut end square & cylindrical. The cut end must be filed or sanded smooth before joining (See Images 14 & 15).

NOTICE Make certain to account for the correct insertion depth when measuring for a cut length of pipe.
2 INCH INSERTION DEPTH FOR DIAMETERS UP TO 12 INCH
3 INCH INSERTION DEPTH FOR DIAMETERS 14 INCH THRU 24 INCH

- i. Measure 2 inches (for diameters up to 12 inch) or 3 inches (for diameters 14 inch thru 24 inch) from cut end and draw a line to indicate depth insertion.
- ii. Insert male end into female end to within ¼ inch of the drawn line to achieve full depth insertion.

WARNING!

Cut pipe joint connections not meeting the full insertion criteria can cause personal injury, death or substantial property damage.

PROPER INSERTION OF MALE END OF CUT TO LENGTH PIPE

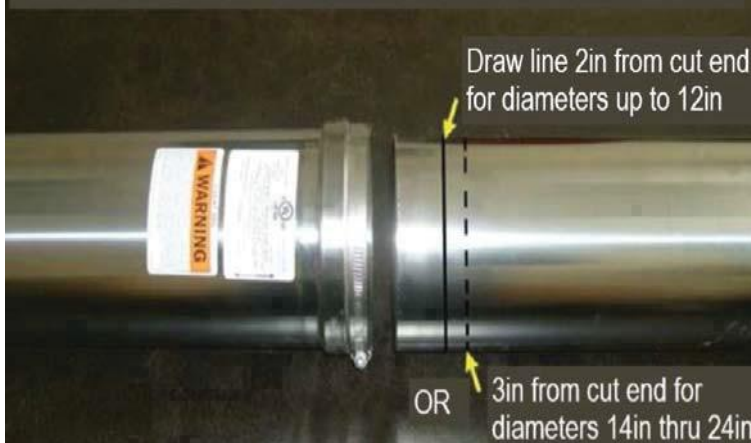

Image 14

INSERTION OF CUT PIPE

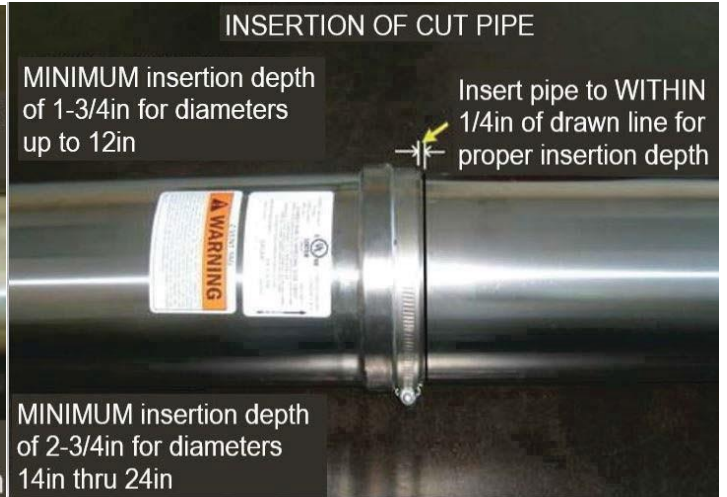

Image 15

NOTICE

Double wall pipe **MUST NOT** be cut. Adjustable pipe must be considered (Refer to the Double Wall Adjustable section on pages 12 & 13).

Single Wall Adjustable:

- ▶ It is recommended to use an adjustable pipe for a non-standard vent length to avoid cutting a vent pipe.
- ▶ Up to 4 inch adjustable pipes are a 2 pipe design and can be installed in any adjacent single wall pipe or fitting.
- ▶ The 5 - 24 inch adjustable pipes are a 1 pipe design and should only be installed into an adjacent single wall pipe (not in any fittings) with a minimum length of 18 inches for the full range of adjustment see Table 5.
- ▶ For 5 - 24 inch, the adjustable slides into the adjacent pipe (See Images 16 & 17) and *should be used on vertical and horizontal runs where possible in order to allow ease of connecting the vent assembly during the final stages.*
- ▶ Support adjustable pipe at each joint outlet especially on vertical runs, ensure adjustable pipe is not subject to any vertical force loads.



Image 16



Image 17

NOTICE

Installer shall mark the minimum insertion depth on a 5-24 inch adjustable pipe and insert to at least this marking.

WARNING!

Neglecting to insert the adjustable pipe to the prescribed insertion depth can result in joint failure.

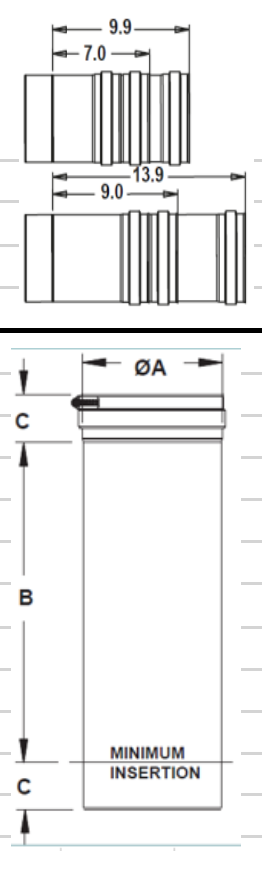
Single Wall Adjustable Part ID	Vent Diameter "A"	Overall Length	Min. Effective Length	Max. Effective Length	Adjustment Range "B"	End Lengths "C"	
2SVSALS3	3	11.90	7	9.90	2.90	2	
2SVSALS4	4	11.90	7	9.90	2.90	2	
2SVSALM3	3	15.90	9	13.90	4.90	2	
2SVSALM4	4	15.90	9	13.90	4.90	2	
2SVSPA05	5	17.75	2*	15.75	13.75	2	
2SVSPA06	6	17.75	2*	15.75	13.75	2	
2SVSPA07	7	17.75	2*	15.75	13.75	2	
2SVSPA08	8	17.75	2*	15.75	13.75	2	
2SVSPA09	9	17.75	2*	15.75	13.75	2	
2SVSPA10	10	17.75	2*	15.75	13.75	2	
2SVSPA12	12	17.75	2*	15.75	13.75	2	
2SVSPA14	14	17.75	3*	14.75	11.75	3	
2SVSPA16	16	17.75	3*	14.75	11.75	3	
2SVSPA18	18	17.75	3*	14.75	11.75	3	
2SVSPA20	20	17.75	3*	14.75	11.75	3	
2SVSPA22	22	17.75	3*	14.75	11.75	3	
2SVSPA24	24	17.75	3*	14.75	11.75	3	

* Single Wall Z-Vent Pipe with a Minimum of 18" Length Required For Full Adjustment Range

Table 5: Single Wall Adjustable Pipe Dimensions (inches)

Double Wall Adjustable:

- ▶ Up to 4 inch adjustable pipes are a 2 pipe design and can be installed into any adjacent double wall pipe or fitting.
- ▶ The 5 - 24 inch adjustable pipes are a 1 pipe design and should be installed into an adjacent double wall pipe with a minimum length of 18 inches for the full range of adjustment see Table 6 and Images 18 - 21.
- ▶ Following the double wall pipe connection instructions on pages 6 & 7, make certain that the 5 - 24 inch adjustable pipes are inserted to the full insertion depth for the required diameter, see images 18 & 20.
- ▶ For 5 - 24 inch, once the proper length is achieved with the adjustable pipe, the adjustment sleeve can slide to close the outer wall: for Snap-Lock slide sleeve until the inner bead clicks with the locks or for ZV-Clamp slide sleeve until flanges touch install ZV-Clamp over flanges and tighten ZV-Clamp bolts.
- ▶ Lock slider in place by tightening gear clamp.

Double Wall Adjustable: 5 - 24 Inch

WARNING! Installer shall mark the minimum insertion depth on the double wall adjustable pipe and insert to at least this marking; 2 inches for up to 12 inch diameters or 3 inches for 14 inch to 24 inch diameters see images 18 & 20. **Neglecting to insert adjustable pipe to the prescribed insertion depth may result in joint integrity failure.**

WARNING! Adjustable pipes should not be inserted into a tee, elbow or any other fitting **past the prescribed insertion depth** see images 18 & 20. Inserting the adjustable pipe **TOO FAR** into a tee, elbow or any other fitting **BEYOND** the prescribed insertion depth **WILL** constrict the vent size in the tee, elbow or any other fitting thereby choking the exhaust gases.

CAUTION! Where a double wall non-standard length is required the **inner** pipe of the Double Wall Adjustable Pipe may be cut, resulting in a non-standard fixed length. Refer to section "**TO CUT PIPE FOR SINGLE WALL ONLY**" on pages 10 & 11. Once the cut is completed, insert inner wall into a tee, elbow or any other fitting **to the prescribed insertion depth** (see images 18 & 20) and slide the outer wall closed to engage the snap lock or mating flanges of ZV-Clamp and install/tighten ZV-Clamp and/or gear clamp.

Double Wall Adjustable SNAP-LOCK:

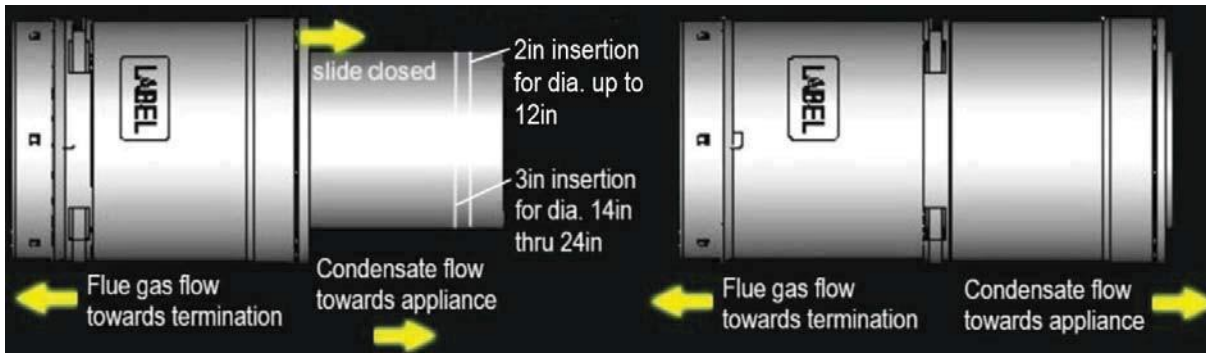

Image 18

Image 19

Double Wall Adjustable ZV-CLAMP:

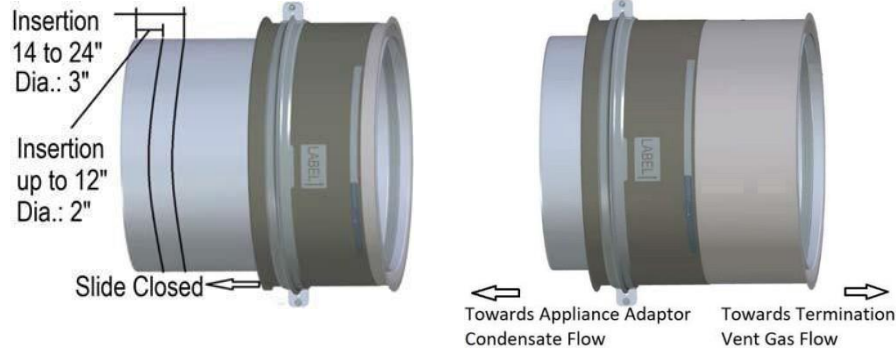

Image 20

Image 21

Double Wall Adjustable SNAP-LOCK Part ID	Double Wall Adjustable ZV-CLAMP Part ID	Vent Diameter "A"	Double Wall Overall Length	Double Wall Min. Effective Length "B"	Double Wall Max. Effective Length "C"	Double Wall Adjustment Range	End Length "D"	
2SVDALM3		3	16	9	13.9	4.9	2	
2SVDALM4		4	16	9	13.9	4.9	2	
2SVDPA05		5	17.75	9*	15.5	6.5	2	
2SVDPA06	2SVDPA06V	6	17.75	9*	15.5	6.5	2	
2SVDPA07	2SVDPA07V	7	17.75	9*	15.5	6.5	2	
2SVDPA08	2SVDPA08V	8	17.75	9*	15.5	6.5	2	
2SVDPA09	2SVDPA09V	9	17.75	9*	15.5	6.5	2	
2SVDPA10	2SVDPA10V	10	17.75	9*	15.5	6.5	2	
2SVDPA12	2SVDPA12V	12	17.75	9*	15.5	6.5	2	
2SVDPA14	2SVDPA14V	14	17.75	9*	14.5	5.5	3	
2SVDPA16	2SVDPA16V	16	17.75	9*	14.5	5.5	3	
2SVDPA18	2SVDPA18V	18	17.75	9*	14.5	5.5	3	
2SVDPA20	2SVDPA20V	20	17.75	9*	14.5	5.5	3	
2SVDPA22	2SVDPA22V	22	17.75	9*	14.5	5.5	3	
2SVDPA24	2SVDPA24V	24	17.75	9*	14.5	5.5	3	

* Double Wall Z-Vent Pipe with a Minimum of 18" Length Required For Full Adjustment Range

Table 6: Double Wall Adjustable Pipe Dimensions (inches)

Condensate Tube Installation:

- ▶ The Z-Flex Silicone Tube Kit contains: 3/8 inch ID tube (various lengths), 1 hose (wire) clamp 1/2 inch, 2 cable ties.
- ▶ When installing the condensate tube be sure to make a trap by forming at least a 3 inch (75 mm) diameter loop and secure with cable tie.
- ▶ Fill the p-trap loop with water • Place hose clamp over the end of the tube • Attach the tube to the spigot of the drain cap
 - Using standard pliers pinch the hose clamp and slide towards the tube / spigot connection and release. (See Images 22 & 23)

Note:

This tube must be 3/8 inch ID high temperature silicone for at least the first 6 inches (152 mm) for category III systems. Alternate tubing having a minimum temperature rating of 300°F ≈ 150°C may be used on category II & IV systems.

- ▶ Check the local codes / regulations to determine how the effluent (condensate fluid) is to be drained.

NOTICE

Local regulations may require the use of a neutralizer kit when using a condensate trap. A condensate pump may also be required. Contact your heating appliance manufacturer or local distributor for a neutralizer kit if required.

IMPORTANT:

- ▶ **Installer must demonstrate to the resident** how to periodically check the p-trap loop(s) during the operating months to make certain that that it is free flowing and filled with water. This will ensure the flow of condensate and:
 - a) Prevent the exhaust gases venting through the drain fitting in a positive pressure vent system (Category III / IV).
 - b) Prevent the suction of mechanical room air through the drain fitting in a negative pressure system (Category II).

NOTICE

Z-Flex® recommends that a condensate drain of suitable configuration be installed in the venting system so that any condensate produced in the vent system is allowed to drain from the vent system before collecting in the appliance.

Drain Assembly with p-Trap (Single Wall Pipe shown)

NOTE: IT MAY BE REQUIRED TO HAVE MORE THAN ONE CONDENSATE DRAIN ON A LONG VENT RUN IN ORDER TO DRAIN THE CONDENSATE FROM THE SYSTEM AS QUICKLY AS POSSIBLE.

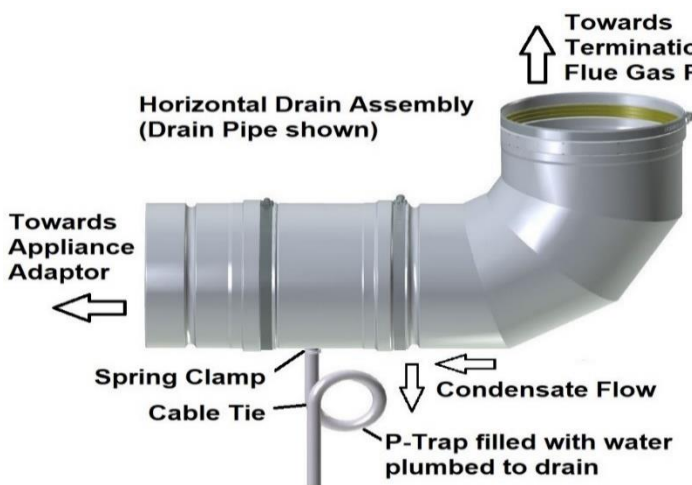

3/8" I.D. Silicone Tube Kit 2SVEDTKX
Image 22

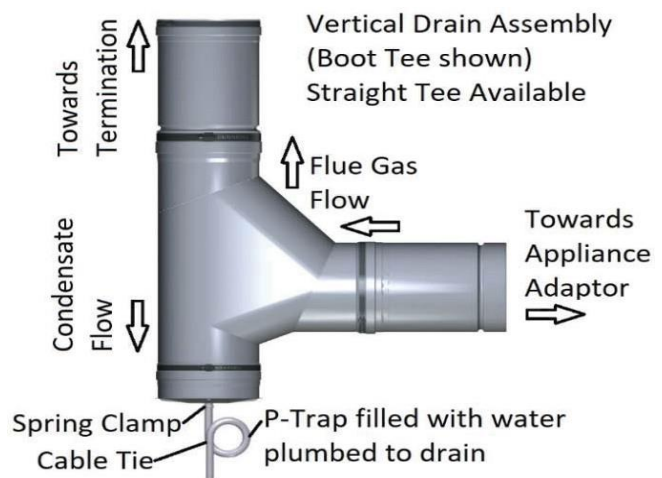

3/8" I.D. Silicone Tube Kit 2SVEDTKX
Image 23

Support Systems: - see other sections for additional support information

Vertical runs shall be supported:

- at base of vertical runs with the following appropriate support: 2SVSFBS__ - Floor Support where transition tee is in an open space or 2SVSBS__ - Base (Wall) support where the transition tee is running up along a wall or 2SVSWS__ - Vent Support in close proximity to the transition tee
- along the riser height to alleviate weight bearing load on the appliance vertical outlet with the following appropriate support: 2SVSVRS__ V - Vertical Riser Support or 2SVSCB__ Clamp Band Support (threaded rod or wire cabling by others)
- at single wall adjustable pipe joint outlet such that the weight of the vent system does not affect the adjustment range within the adjacent pipe: 2SVSVRS__ V - Vertical Riser Support or 2SVSCB__ Clamp Band Support (threaded rod or wire cabling by others)
- at every ceiling / floor with 2ZVFSS__ - Firestop Support or 2SVSCB__ Clamp Band Support for noncombustible applications
- at roof if necessary with Roof Jack Support 2SV(S,D)RJ__ and Storm Collar (Top Support) 2SVLS__ and Guy Band 2SVSGB__ if vent is 6 ft. above roof

For vertical runs a support is required every 16 ft. (4.88m) or less of vertical height.

Horizontal runs must be supported:

- within 1 ft. of appliance adaptor with Wall Support 2SVSWS__
- at floor if appropriate with Floor Base Support 2SVSFBS__
- at every elbow with Wall Support 2SVSWS__

For horizontal runs a support is required every 48" (every 60" for Double Wall with ZV-CLAMP) or less of horizontal length.

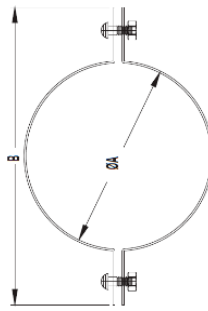
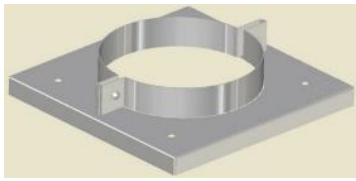

Base (Wall) Support
2SVSBS__

Vertical Rise Support
2SVSVRS__V

Clamp Band
2SVSCB__

Wall Support
2SVSWS__

Storm Collar (Top Support)
2SVSLS__

NOTICE

Loose metal strapping can be used for horizontal supports, see Illustration 3. It's recommended to use strapping made of similar material to the vent pipe (stainless steel) to minimize galvanic corrosion of the support system. Maintain clearance to combustibles as per Table 2 on page 7.

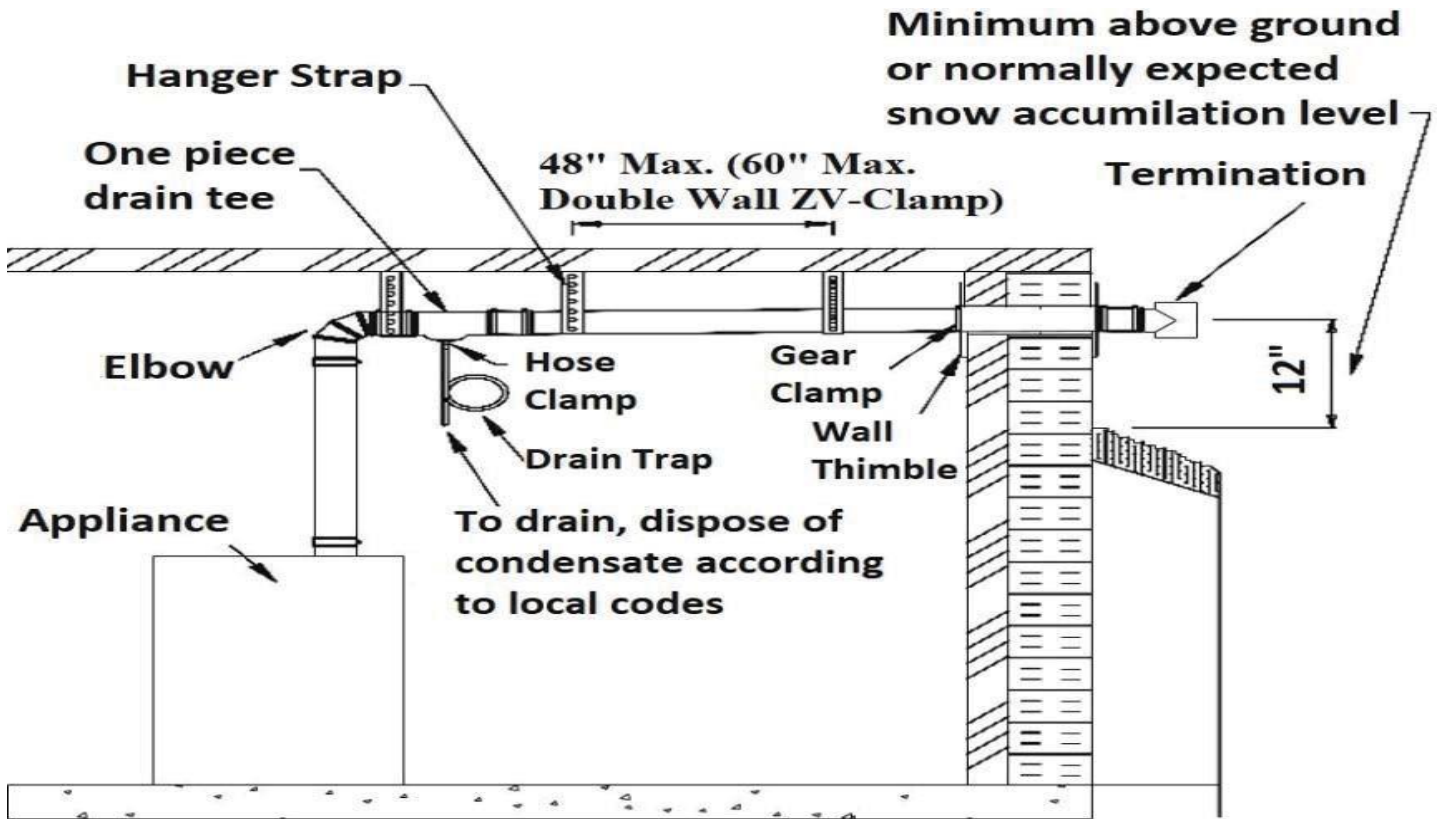

Illustration 3

INSTALLATION OF HORIZONTAL SUPPORTS

IMPORTANT: The vent system **MUST** be supported **DURING THE POINT OF INSTALL.**

Example:

- 1) From your selected termination point at the wall you can prepare your support locations by temporarily placing one end of a straight length of wood such as a 2" x 2" or 2" x 4" or broom handle in the prepared termination location.
- 2) Lower the other end of this length of wood to make certain that you have sloped / pitched your horizontal run properly. (minimum ¼ inch per foot slope)
- 3) Affix your hanger supports at the proper intervals. I.E. At each "directional change" and every 48 inches
- 4) Install pipe and or fittings through the supports during assembly.

VERTICAL VENTING INSTALLATION

- ▶ Single wall vent terminations above the roof line must be at least 3 ft. (.9m) high to a maximum of 6 ft. (1.8 m) without the use of lateral supports and 2 ft. (.61 m) higher than any part of a structure within 10 ft. (3.1 m).
 - ▶ Each pipe joint above the roof shall be connected using the coupling / guy band assembly, except double wall with ZV-Clamp.
 - ▶ Vertical heights greater than 6 ft. above the roof shall have guy wires connected to the coupling / guy band assembly at 6 ft. intervals. Fasten Guy wires of stainless steel or galvanized cable with a minimum capacity of 500 lbs. to each of the four anchor holes that is integral to the coupling / guy band assembly and anchor to the roof structure using the appropriate fastening method.
 - ▶ The total vertical distance of the vent system from appliance flue collar to the rain cap termination and the maximum length of offsets shall not exceed that specified in the appliance manufacturer's installation instructions.
 - ▶ All horizontal sections must observe the rules for **HORIZONTAL VENTING**.
1. Prior to beginning the installation, loosely assemble all parts required to make sure **all** parts are present.
 2. Review the venting requirements section in the appliance manufacturer's installation & operating manual to determine the vent system configuration.
 3. Select and apply the appliance adaptor to the flue outlet collar of the appliance.
 4. Locate and mark the breach location(s) of the vertical stack for Firestop Spacer(s) and/or Firestop Spacer Support(s) and Roof Jack Support. Refer to sections:
 - i) **INSTALLING FIRESTOP SPACER / SUPPORT**
 - ii) **INSTALLING ROOF JACK SUPPORT SYSTEM**
 5. Install the required Firestop Spacer(s) and/or Firestop Spacer Support(s) and Roof Jack Support per the instruction listed above.
 6. Continue connecting the required lengths of pipe and fittings starting from the appliance adaptor throughout the system making certain to follow the instructions in this guide with respect to i) Clearances ii) Joint Procedure, ii) Slope iii) Drain Traps iv) Supports and vi) Vertical Termination.
 7. Where a vent pipe is to install through a Firestop Spacer Support. Insert vent pipe with male end through clamp and plate(s) of Firestop Spacer Support and into female end of mating pipe with gasket. Tighten gear clamp or clamp hardware ensuring proper positioning of vent pipe including any horizontal slope, see Installing Firestop Spacer / Support Plate(s) for additional details.
 8. Where the vertical system is to install through the Roof Jack Support System refer to the section **INSTALLING ROOF JACK SUPPORT SYSTEM**.
 9. Repeat step 6.
 10. Where the vent passes through the Roof Jack Support System extend the pipe above the roof following the Vertical Termination Clearances. (See Illustration 2)
 11. Install the Storm Collar (Top Support) and, if necessary the Flashing on the pipe just above the Roof Jack Support assembly and seal around the top edge where the collar meets the pipe.
 12. Affix the vertical termination following the Joint Procedure (pages 5 - 7).

INSTALLING FIRESTOP SPACER / SUPPORT PLATE(S)

NOTICE

A Firestop Spacer or Firestop Spacer Support must be provided when a vent passes through a combustible floor or ceiling. The opening must be framed to receive the integrated spacer brackets of the Firestop Spacer / Support.

- ▶ The Firestop Spacer / Support plate is shipped as a flat square plate or plate halves with all brackets flat.
 - i. Bend 4 Spacer brackets downwards; when design includes 2 sets of 4 spacer brackets refer to Heating System Operating Specifications to determine the system maximum vent gas temperature and select the appropriate set of 4 spacer brackets marked with temperature (480°F outer brackets or 300°F inner brackets) . (See Image 24)
 - ii. When design includes support clamp brackets on the plate. The support clamp is to be loosely bolted to (or through) support clamp brackets. Select the appropriate support clamp brackets and bend upwards (and around clamp for center hole brackets). (See Images 24 & 25)

Spacer Brackets Bend Downwards: 4 Outer for 480F Max Vent Gas Temp. or 4 Inner for 300F Max Vent Gas Temp.

Support Clamp Brackets Bent 2 Upwards and Attach Support Clamp

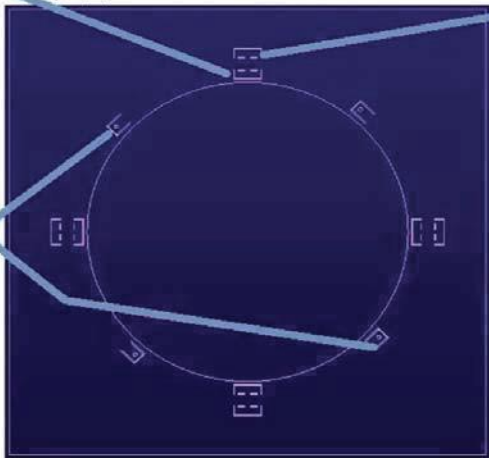

Image 24

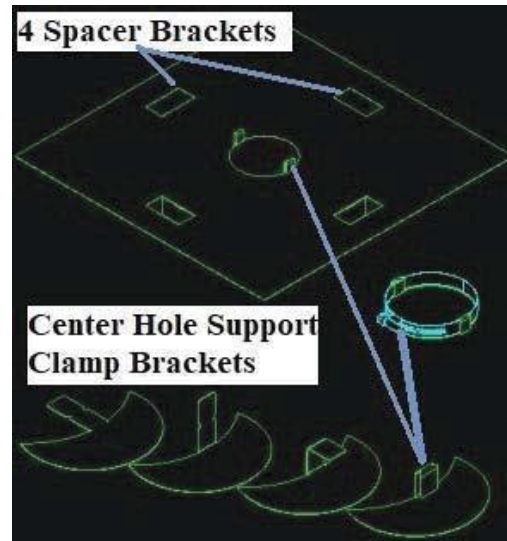

Image 25

- ▶ Measure the dimensions of the selected spacer brackets to determine the hole size that must be cut into the floor or consult Table 7 if part I.D. matches.
- ▶ Transfer this dimension to the predetermined breaching floor locations and cut hole.
- ▶ Cut a square hole and clear any flooring material so that a proper frame can be installed.
 - i. When cutting the opening, allowance must be made for the thickness of the frame and frame the opening of the floor using lumber, which is dimensionally consistent with the structural members.

NOTICE

In the event that floor joists must be cut follow the building codes having jurisdiction for reframing the opening.

- ▶ A support clamp is supplied with a Firestop Spacer Support. The support clamp is to be installed around vertical pipe (and to or through support clamp brackets when include) just above the top of the Firestop Spacer Support plate(s).
- ▶ Install vertical vent pipe through center hole of Firestop Spacer plate(s) with 4 spacer brackets facing downward. When design has 2 plate halves, interlock 2 spacer brackets between Firestop Spacer plates.
- ▶ Secure Firestop Spacer plates(s) to top of framed opening using the appropriate drill and screws.
- ▶ Complete pipe connections.
- ▶ Check the height and or level of the vent for correctness and tighten the Firestop Spacer Support clamp as it rests on the plate(s).
- ▶ Seal any openings in Firestop Spacer / Support including around outer vent pipe and firestop/ceiling/joists with field supplied firestop sealant. Discuss sealant and assembly with firestop professional and local building and fire officials to ensure fire stop meets with local code requirements. (See Image 26)

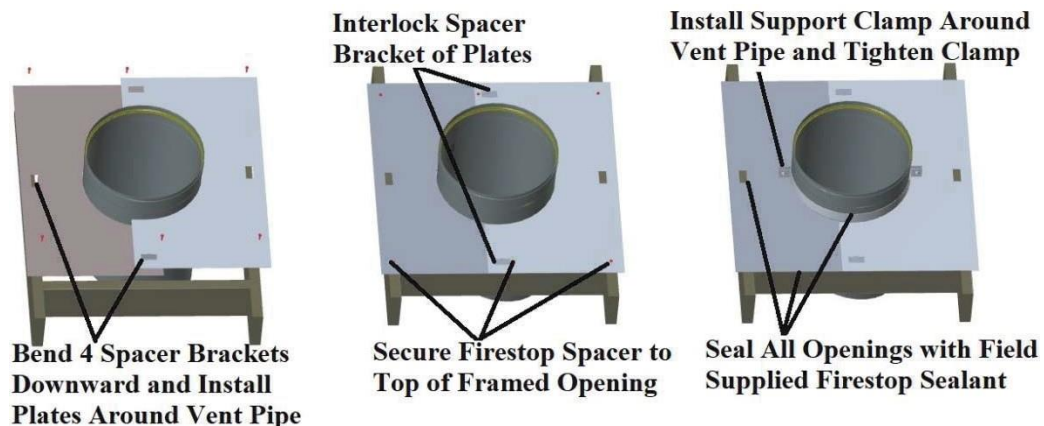

Image 26

Firestop Part ID	Firestop Support Part ID	Single Wall or Double Wall (Inner/Outer) Diameter (Nominal)	Single Wall or Double Wall Outer to Combustible Clearance	Combustible Ceiling Inside Opening MINIMUM	Fire Stop Outer Plate Dimensions	Maximum Vent Gas Temperature
2ZVFS03	2ZVFSS03	3"	4"	11" x 11"	16" x 16"	480°F
2ZVFS04	2ZVFSS04	4"	4"	12" x 12"	17" x 17"	480°F
2ZVFS05	2ZVFSS05	5" or 3"/5"	4"	13" x 13"	18" x 18"	480°F
2ZVFS064DW	2ZVFSS064DW	4"/6"	4"	14" x 14"	19" x 19"	480°F
2ZVFS075DW	2ZVFSS075DW	5"/7"	4"	15" x 15"	20" x 20"	480°F
2ZVFS06	2ZVFSS06	6"	6"	18" x 18"	23" x 23"	550°F
2ZVFS07	2ZVFSS07	7"	6"	19" x 19"	24" x 24"	550°F
2ZVFS08	2ZVFSS08	8" or 6"/8"	6"	20" x 20"	25" x 25"	550°F
2ZVFS09	2ZVFSS09	9" or 7"/9"	6"	21" x 21"	26" x 26"	550°F
2ZVFS10	2ZVFSS10	10" or 8"/10"	6"	22" x 22"	27" x 27"	550°F
2ZVFS11	2ZVFSS11	9"/11"	6"	23" x 23"	28" x 28"	550°F
2ZVFS12	2ZVFSS12	12" or 10"/12"	6"	24" x 24"	29" x 29"	550°F
2ZVFS14	2ZVFSS14	14" * or 12"/14"	6"	26" x 26" *	31" x 31"	550°F 12"/14" Double Wall, *300°F or Non-Combustible Material 14" Single Wall
2ZVFS16	2ZVFSS16	16" or 14"/16"	6"	28" x 28" *	33" x 33"	*300°F or Non-Combustible Material
2ZVFS18	2ZVFSS18	18" or 16"/18"	6"	30" x 30" *	35" x 35"	*300°F or Non-Combustible Material
2ZVFS20	2ZVFSS20	20" or 18"/20"	6"	32" x 32" *	37" x 37"	*300°F or Non-Combustible Material
2ZVFS22	2ZVFSS22	22" or 20"/22"	6"	34" x 34" *	39" x 39"	*300°F or Non-Combustible Material
2ZVFS24	2ZVFSS24	24" or 22"/24"	6"	36" x 36" *	41" x 41"	*300°F or Non-Combustible Material
2ZVFS26	2ZVFSS26	24"/26"	6"	38" x 38" *	43" x 43"	*300°F or Non-Combustible Material

Table 7: Firestop Spacers & Firestop Spacer Supports

INSTALLING ROOF JACK SUPPORT SYSTEM

NOTICE

The Roof Jack Support System is available from 5" thru 24" and is recommended to be used on all through the roof vent terminations having multiple joints above the roof line with combustible or non-combustible roof structures.

- Prepare the breach location of the roof that will accept the Roof Jack Support System by drilling a small hole, marking the center of the vent termination. Refer to Table 8 for Roof Jack Support System Dimensions and Table 9 for Roof Jack Support System maximum vent gas temperature, combustible clearance and minimum inside opening for framing.

PART ID	A	B	C	D	E (Square)	F	Image
2SVSRJ05	5"	10"	12.5"	6"	20"	6"	
2SVSRJ06	6"	11"	13"	7"	21"	6"	
2SVSRJ07	7"	12"	14"	8"	21.5"	6"	
2SVSRJ08	8"	13"	14.5"	9"	23"	6"	
2SVSRJ09	9"	13"	14.5"	10"	23"	6"	
2SVSRJ10	10"	14"	15"	11"	23.5"	6"	
2SVSRJ12	12"	16"	16.5"	13"	25.5"	6"	
2SVSRJ14	14"	18"	19"	15"	27"	6.8"	
2SVSRJ16	16"	20"	21"	17"	28.5"	6.8"	
2SVSRJ18	18"	22"	23"	19"	30"	6.8"	
2SVSRJ20	20"	24"	24"	21"	31.5"	6.8"	
2SVSRJ22	22"	26"	25.5"	23"	33"	6.8"	
2SVSRJ24	24"	28"	27"	25"	37"	6.8"	
2SVDRJ05	5"	9"	11.5"	8"	19.5"	6"	
2SVDRJ06	6"	10"	12.5"	9"	20"	6"	
2SVDRJ07	7"	11"	13.5"	10"	21"	6"	
2SVDRJ08	8"	12"	14"	11"	21.5"	6"	
2SVDRJ09	9"	13"	14.5"	12"	22"	6"	
2SVDRJ10	10"	14"	15"	13"	23"	6"	
2SVDRJ12	12"	16"	16.5"	15"	24.5"	6"	
2SVDRJ14	14"	18"	19.5"	17"	27"	6.8"	
2SVDRJ16	16"	20"	21"	19"	28.5"	6.8"	
2SVDRJ18	18"	22"	22.5"	21"	30"	6.8"	
2SVDRJ20	20"	24"	24.5"	23"	31.5"	6.8"	
2SVDRJ22	22"	26"	26.5"	25"	33"	6.8"	
2SVDRJ24	24"	28"	28.5"	27"	36"	6.8"	

Table 8: Roof Jack Support System Dimensions

PART ID	Maximum Vent Gas Temperature	Roof Jack "B" to Combustible Clearance	Combustible Inside Opening MINIMUM	OR	Maximum Vent Gas Temperature	Roof Jack "B" to Combustible Clearance	Combustible Inside Opening MINIMUM
2SVSRJ05	480°F	0"	10" x 10"			550°F	0.5"
2SVSRJ06	480°F	0"	11" x 11"		550°F	0.5"	12" x 12"
2SVSRJ07	480°F	0"	12" x 12"		550°F	0.5"	13" x 13"
2SVSRJ08	480°F	0"	13" x 13"		550°F	0.5"	14" x 14"
2SVSRJ09	480°F	0"	13" x 13"		550°F	1"	15" x 15"
2SVSRJ10	480°F	0"	14" x 14"		550°F	1"	16" x 16"
2SVSRJ12	480°F	0"	16" x 16"		550°F	1"	18" x 18"
2SVSRJ14	300°F	0"	18" x 18"		480°F	1"	20" x 20"
2SVSRJ16	300°F	0"	20" x 20"		480°F	1"	22" x 22"
2SVSRJ18	300°F	0"	22" x 22"		480°F	1"	24" x 24"
2SVSRJ20	300°F	0"	24" x 24"		480°F	1"	26" x 26"
2SVSRJ22	300°F	0"	26" x 26"		480°F	1"	28" x 28"
2SVSRJ24	300°F	0"	28" x 28"		480°F	1"	30" x 30"
2SVDRJ05	480°F	0"	9" x 9"		550°F	1"	11" x 11"
2SVDRJ06	480°F	0"	10" x 10"		550°F	1"	12" x 12"
2SVDRJ07	480°F	0"	11" x 11"		550°F	1"	13" x 13"
2SVDRJ08	480°F	0"	12" x 12"		550°F	1"	14" x 14"
2SVDRJ09	480°F	0"	13" x 13"		550°F	1"	15" x 15"
2SVDRJ10	480°F	0"	14" x 14"		550°F	1"	16" x 16"
2SVDRJ12	480°F	0"	16" x 16"		550°F	1"	18" x 18"
2SVDRJ14	300°F	0"	18" x 18"		480°F	2"	22" x 22"
2SVDRJ16	300°F	0"	20" x 20"		480°F	2"	24" x 24"
2SVDRJ18	300°F	0"	22" x 22"		480°F	2"	26" x 26"
2SVDRJ20	300°F	0"	24" x 24"		480°F	2"	28" x 28"
2SVDRJ22	300°F	0"	26" x 26"		480°F	2"	30" x 30"
2SVDRJ24	300°F	0"	28" x 28"		480°F	2"	32" x 32"

Table 9: Roof Jack Support System Max. Vent Gas Temperature, Clearance to Combustibles & Min. Inside Opening

- ▶ Cut a square hole and clear any roofing material so frame with proper minimum opening can be installed (See Table 9).
- ▶ When cutting the opening, allowance must be made for the thickness of the frame.

NOTICE

In the event that roof joists must be cut - follow the building codes having jurisdiction for reframing the opening.

- ▶ For roof curb installations (recommended): Refer to minimum opening in Table 9 for framing size for masonry pour and Table 8 for roof jack dimensions. Roof curbs may also be purchased at your local building supply store.

INSTALLING ON A FRAMED OPENING

- ▶ Implementing "best practice" and / or "preferred" methods. Drill sufficient holes in the roof jack plate.
- ▶ Place the Roof Jack Support System (conical side up) by centering it over and lowering it down onto the frame and transfer the position of the drilled holes from the plate onto the frame. Temporarily remove the Roof Jack for adhesive application.
- ▶ Apply the appropriate weather resistant adhesive to the frame observing the hole markings.
- ▶ Install the Roof Jack Support System (conical side up) by centering it over the framed opening and lowering it onto the frame and secure it using screws equipped with neoprene washers.
- ▶ Using the appropriate roofing methods reapply the roofing material over the plate to maintain the roofing integrity.
- ▶ Install the flashing over the roof jack by implementing the standard contractor roofing methods.

INSTALLING ON A CURB

- ▶ Implementing "best practice" and / or "preferred" methods. Drill sufficient holes in the roof jack plate.
- ▶ Place the Roof Jack Support System (conical side up) by centering it over and lowering it down onto the curb and transfer the location of the drilled holes from the plate onto the curb. Temporarily remove the Roof Jack. Select the appropriate masonry drill bit size for the concrete screws being used and drill the marked holes in the curb to the prescribed depth.
- ▶ Apply the appropriate weather resistant adhesive to the curb observing the hole markings.
- ▶ Install the Roof Jack Support System (conical side up) by centering it over and lowering it down onto the curb again. This time fasten the plate to the curb with concrete screws equipped with neoprene washers.
- ▶ Seal where the plate meets the curb with the appropriate weather resistant sealant.

INSTALLING VENT PIPE THROUGH ROOF JACK SUPPORT SYSTEM

Where double wall pipe with ZV-Clamp is to be used with a roof jack assembly, do not install the ZV-Clamp inside the roof jack. Instead install mating flanges in slotted sections located in Pipe Joint Range of Roof Jack Coupling assembly (See Illustration 4) supplied with the Roof Jack Support System. Connect the two prescribed lengths of pipe (above and below roof) and couple them together with Roof Jack Coupling Assembly. Position the pipe joint in the notched area of the coupling assembly (See Illustration 5). Tighten the lock-nuts onto the bolts that clamp the assembly onto the pipe to a torque specification of 70 in/lbs. / 6 ft-lbs / 8

- ▶ Lower the pipe assembly maintaining the proper pipe orientation (gasket end up) into the previously installed Roof Jack Support until the coupling assembly is fully seated. (See Illustration 6)

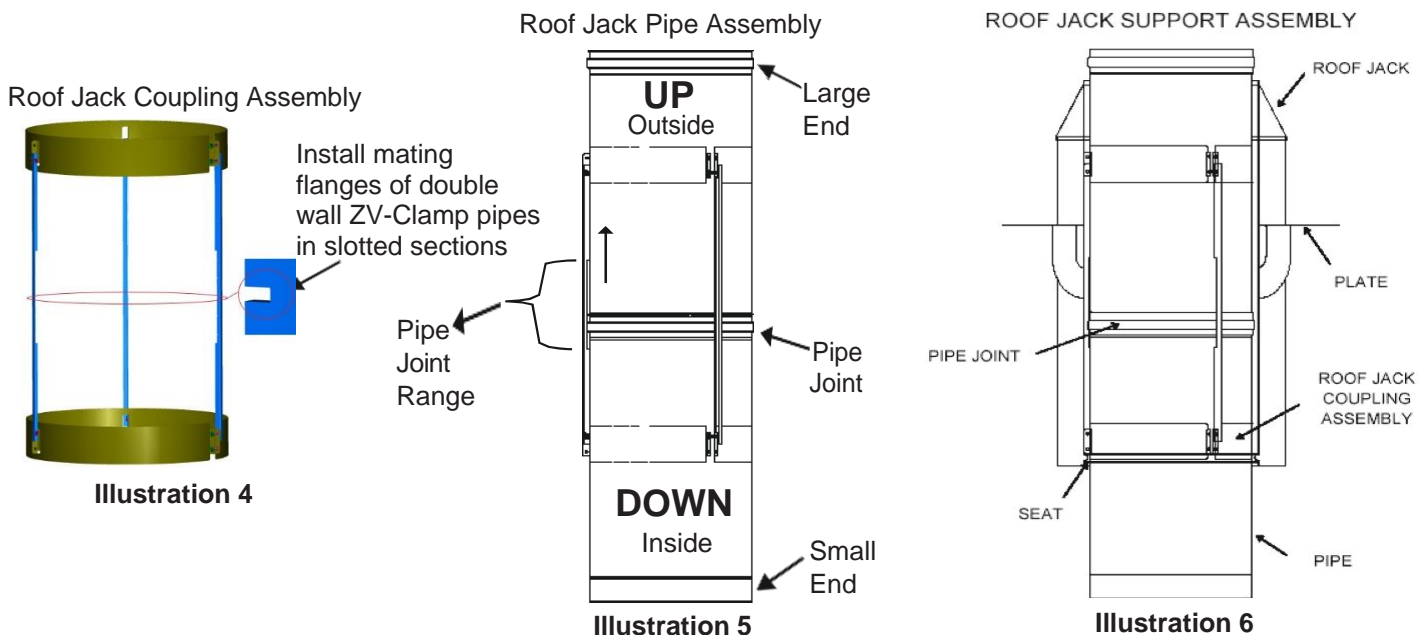

INSTALLING VENT INTO AN EXISTING MASONRY CHIMNEY

NOTICE

A masonry chimney flue may be used to route vent through provided that no other appliance is vented directly into the same flue without a chimney liner.

- ▶ Prior to beginning the installation make certain that the existing chimney meets all national and local building codes.
- ▶ The chimney must be cleaned, removing all soot, debris and creosote before installing vent.
- ▶ It is recommended to have the vent stack supported from the bottom so that the system is in compression.
- ▶ Prepare and install the "preferred" support for receiving the vent system at the bottom of the stack.
- ▶ Following the joint procedure (pages 5 - 7) connect the bottom fitting / pipe together. It is recommended that a guy band coupler assembly be installed (See Illustration 10) every 2nd joint, except on double wall with ZV-Clamp. Implementing "best practice" and / or "preferred" methods assemble the vent system while lowering the flue downwards into the chimney onto the support.
- ▶ Prepare the chimney cap to receive the Flashing. Install the flashing over the last length of pipe down to the chimney cap.
- ▶ Loosely attach the Top Support to the pipe directly above the flashing leaving approximately 6 inches of pipe for the vertical termination connection and any breaching adjustment.
- ▶ Fasten the Flashing to chimney top using caulking and/or screws. If the top clay tile is still in place, the corners of the flashing should be notched and flashing plate formed down around clay tile.
- ▶ Install the vertical termination. Adjust the top support and tighten the collar. Apply sealant to upper edge where the top support collar meets the pipe

Special Fittings

TYPICAL ECCENTRIC INCREASER / SINGLE WALL TO DOUBLE WALL APPLICATION

- ▶ Eccentric Inserter (See Illustration 7) shall be used when increasing the appliance vent diameter or system diameter from one size to a larger size in a "**horizontal application**". (Refer to appliance installation & operating manual and /or engineered approved design)
- ▶ Eccentric Inserter provides a level wall allowing the condensate to flow unimpeded back to drain. (See Vent Pipe Slope page 10)
- ▶ Single Wall to Double Wall fitting is necessary when transitioning from a single wall vent system to a double wall vent system.

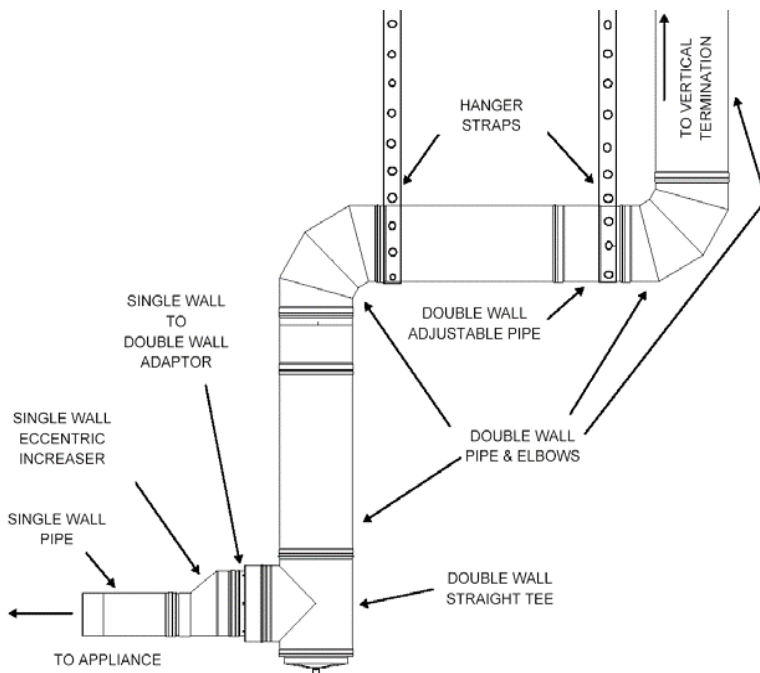

Illustration 7

TYPICAL CONCENTRIC INCREASER APPLICATION

- ▶ Concentric Increases (See Illustration 8) shall be used when increasing the vent diameter or system diameter from one size to a larger size in a "**vertical application**". (Refer to appliance installation & operating manual and /or engineered approved design)
- ▶ Concentric Inserter provides a conical wall allowing the condensate to flow vertically unimpeded back to drain. (See Vent Pipe Slope page 10)

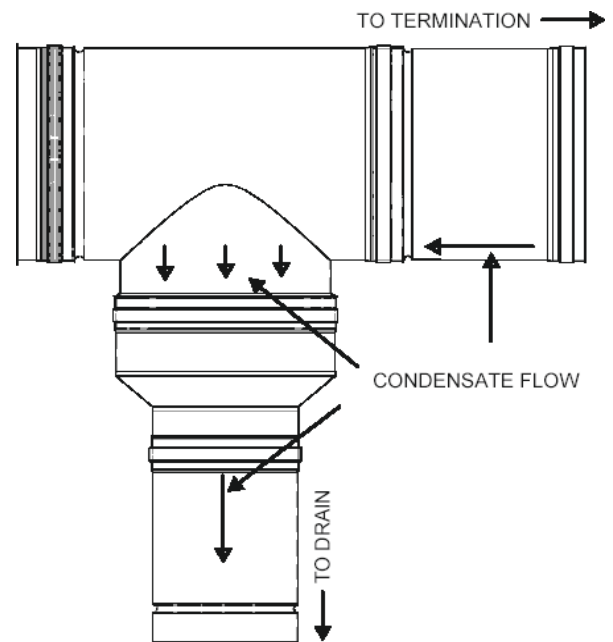

Illustration 8

TYPICAL THROUGH THE ROOF STACK TERMINATION

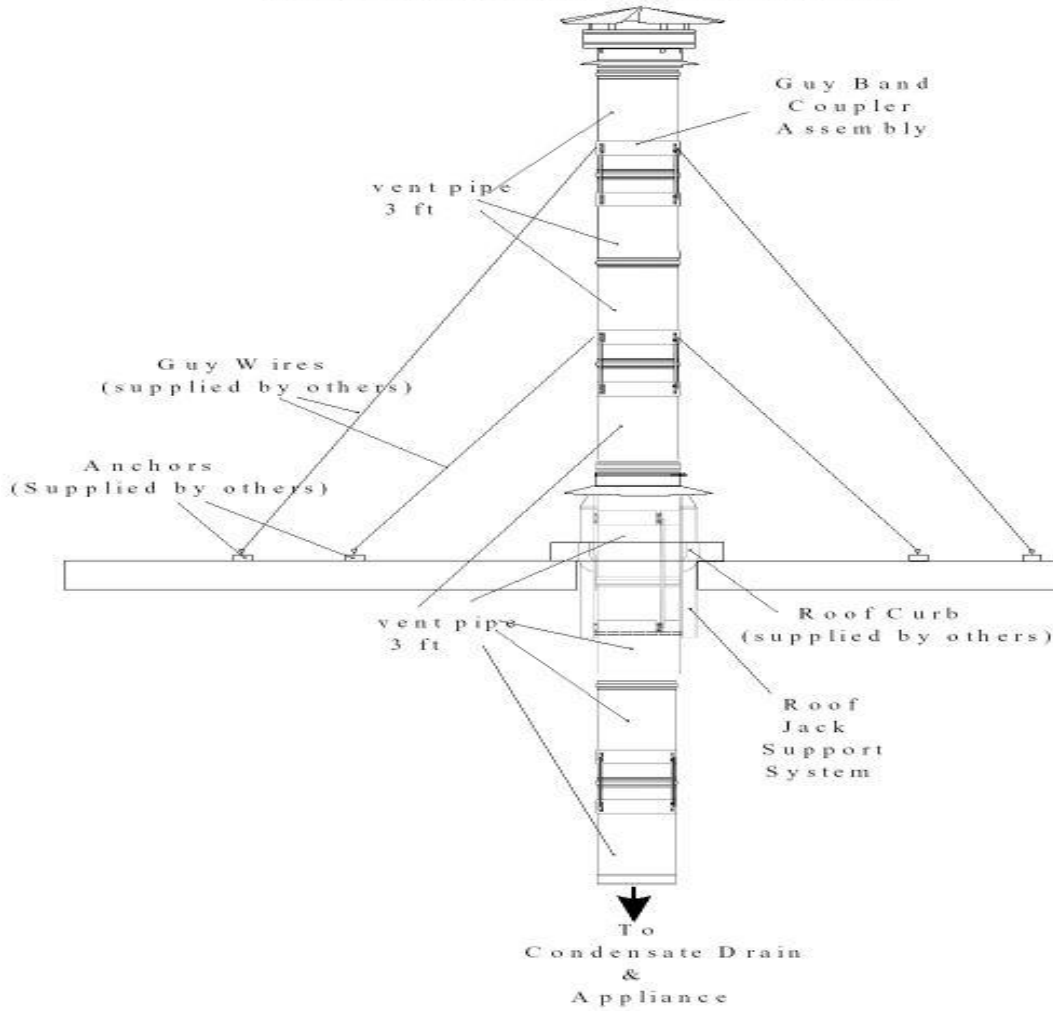
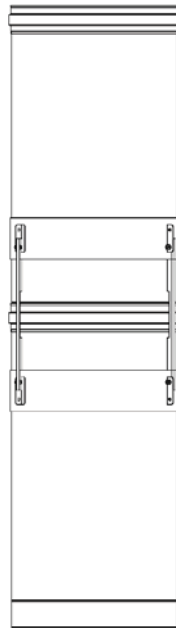
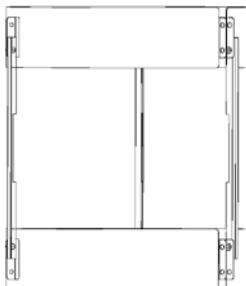

Illustration 9

**Guy Band Coupler Support
Part ID - 2SVSGBS__
(See Illustration 10)**

This guy band coupler can be used in the vertical & horizontal orientation providing additional rigidity & support when in final position (guy wires by others). Not required on double wall with ZV-Clamp unless vent is mounted exterior 6 feet above the roof.



Tighten the lock-nuts onto the bolts that clamp the assembly onto the pipe to a torque specification of 70 in/lbs. / 6 ft-lbs. / 8 Nm.

Illustration 10

TYPICAL VENT THROUGH MASONRY CHIMNEY APPLICATION

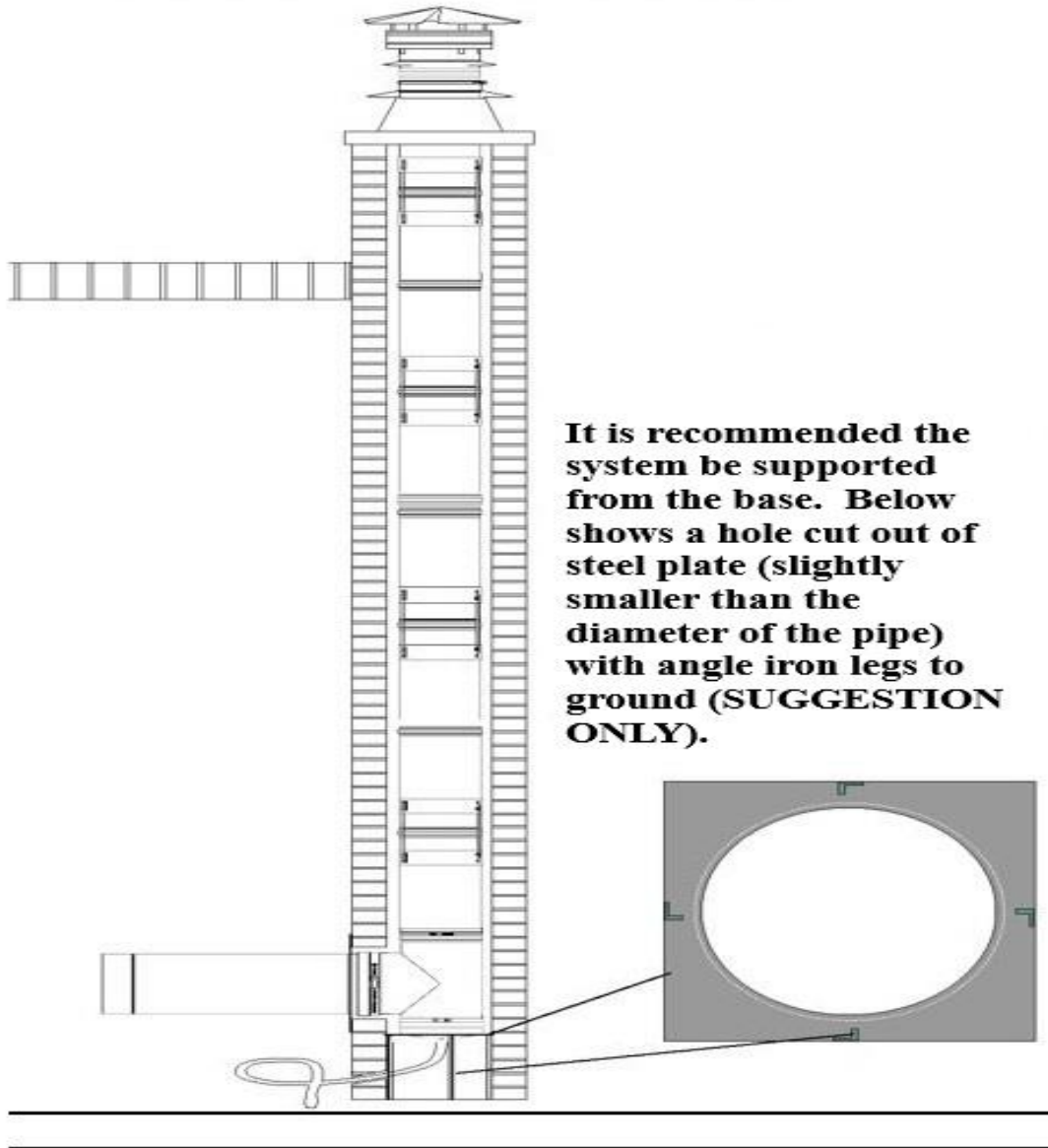

Illustration 11

Floor / Base Support
Part ID - 2SVSFBS__
(See Illustration 12)

Center the Floor / Base Support under the Vertical Tee making the necessary height adjustment to maintain the proper slope of the vent system.

CAUTION!

Installer is to allow sufficient space below the Floor / Base Support to properly install the Drain tube with prescribed P-Trap configuration. (See page 14)

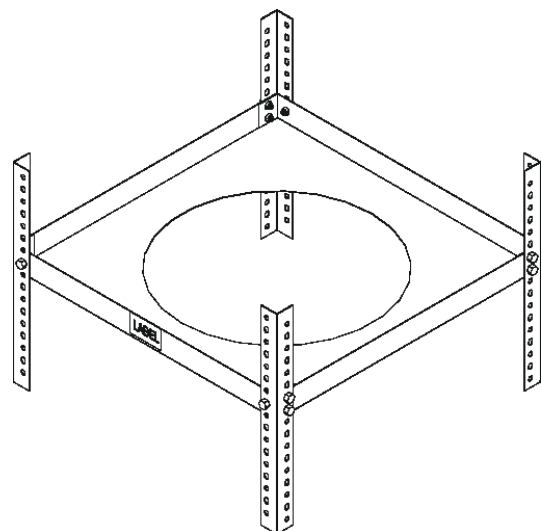

Illustration 12

Z-Vent® Smoothcore® Installation

NOTICE

The Z-Vent® Smoothcore® liner must be installed vertically with a maximum offset of 45° in an unused, clean, structurally sound masonry or factory built chimney and transition to Z-Vent® Single Wall vent at chimney breach. Z-Vent® Smoothcore® is available in 4, 5, 6, 7, 8, 9, 10, 12 inch diameters. For 4 to 8 inch diameters in a single continuous length up to 35 ft. For 9 to 12 inch diameters, liner lengths are to be achieved in sections of which the longest kit length will be 15 ft and additional sections will be 10 ft. This is due to shipping constraints as well as physical handling and installing. Crating will be necessary and is an additional charge. For all diameters additional lengths are to be joined in the field by affixing the 2SVFCON_ _ as prescribed on page 25. Z-Vent® Smoothcore® liner is directional with male connector towards appliance.

Parts: **2SVFLXCN** _ _ _ - Z-Vent® Smoothcore® Flex with Male Connector Φ X length
 Diameter ← → Length
2SVFCON _ _ - Z-VENT® FEMALE GSKT CONNECTOR Φ

1. The Z-Vent® Smoothcore® liner is supplied with a male connector on one end. This male end is always the lowest part of the liner. (See Illustration 13)
2. The female connector has a gasket and is designed for the top of the Smoothcore® Flex liner. (See Illustration 14)

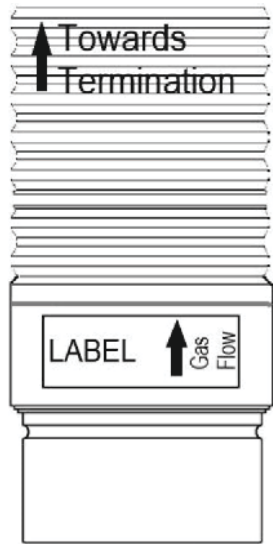

Smoothcore® /w Male Connector
Illustration 13

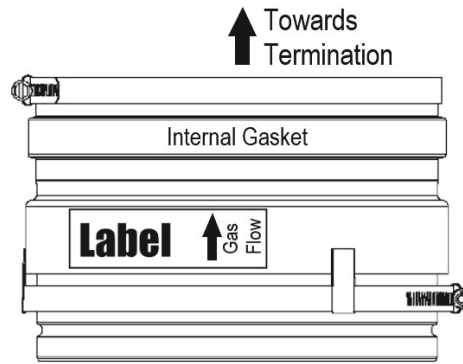

Female Connector
Illustration 14

3. Above parts are to be connected using the prescribed sealant supplied with the Smoothcore® Flex. Read and follow the application instructions carefully. **Note:** The connecting parts must adhere within 15 minutes of applying the sealant and to allow for proper curing time of the sealant after joint application prior to installing the liner.

FIELD CUTTING THE SMOOTHCORE® FLEX

1. The Smoothcore® flex is supplied with the male connector on one end.
2. If it is necessary to field cut the liner, make certain the cut is square. **DO NOT FOLLOW** the corrugation grooves as a guideline.
3. Simply measure the length needed from the male end of the flex and with a permanent marker mark around the flex every 90°.
 - i. Use adhesive tape to wrap around the liner along these marks making sure to match up your start & end points of the tape.
 - ii. Using the appropriate cutting tool cut along the edge of the tape 360°.

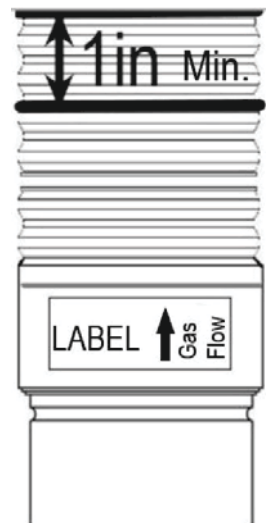

Illustration 15

AFFIXING THE FEMALE CONNECTOR ONTO THE SMOOTHCORE® FLEX

1. Measure 1 inch from the end of the usable length and mark around the flex every 90° with a permanent marker joining the marks to make a continuous line. This is the minimum insertion depth. (See Illustration 15)
2. Perform a dry fit by inserting the flex into the female adaptor until it bottoms out. Make note of where the marking lines up.
3. Read the instructions on the supplied 10 oz. sealant tube (1 per Female Connector).
4. Trim the nozzle tip so that it is able to *insert* in-between the inner and outer wall of the female connector and load tube in a caulking gun. (See Illustration 16 & Image 27)
 - i. It may be easier to remove the gear clamp from the brackets when applying the sealant.
5. Using a caulking gun compress the tube *liberally* injecting a constant bead of sealant in-between the inner and outer wall of the connector while circling entirely around the connector. Do not leave gaps in the bead of sealant. Continue to inject the sealant while circling around the connector *until the channel is filled* with the sealant.
6. Place the female connector on the liner where the inner wall of the connector fits inside the flex and the outer wall of the connector fits outside the flex. (See Images 28-31)
 - i. Press down evenly and firmly until the connector lines up or is over the previously noted minimum insertion depth mark on the flex liner. The sealant will rise as the liner is pressed down.
 - ii. Once the liner has bottomed down smooth the sealant in-between the outer wall and the liner completely around the minimum insertion point.
7. Re-install gear clamp if removed in step 4.i. and tighten.



Illustration 16



Image 27



Image 28

Image 29

Image 30

Image 31

8. Prior to installation, let the assembly cure for the minimum 24 hours or follow the cure time specified by the approved sealant manufacturer.

JOINING 2 LENGTHS OF SMOOTHCORE® FLEX

1. Follow the Instructions above for AFFIXING THE FEMALE CONNECTOR ONTO THE SMOOTHCORE® FLEX prior to joining 2 assembly lengths.
2. After the 24 hour cure time, simply evenly insert the small end male connector into the gasketed end of the female connector. You will meet some resistance when in contact with the gasket. Continue to insert until fully seated. (See Illustration 17)

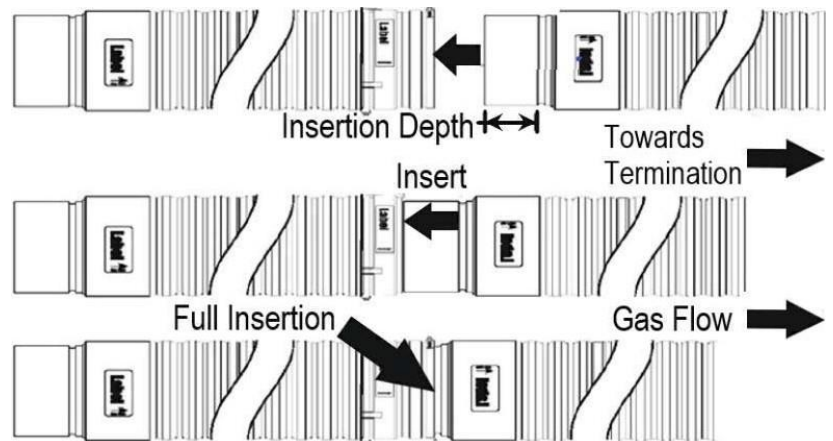

Illustration 17

Supports Systems:

The support system for the liner should be considered by this point in the install.

- A support system such as below the breaching point in the wall for the system to rest on.
- A support system such as suspending guy wires from an anchor plate at the chimney top affixed to guy bands around the flex liner.

SMOOTHCORE® FLEX TYPICAL INSTALLATION

Advisory: For the reasons of safety and quality of installation, the flex liner system should be installed with two persons, one person lowering the liner from the top of the masonry chimney, while the other person pulls the liner down from below.

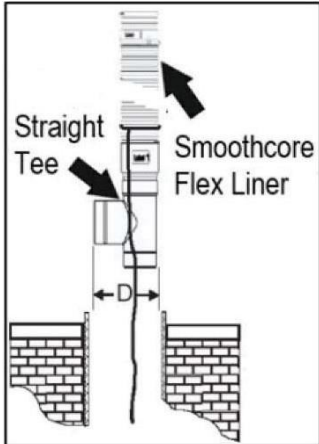

Illustration 18

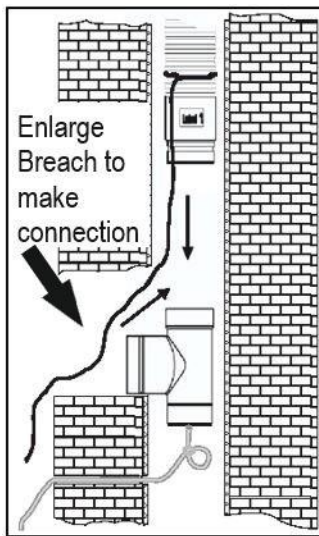

Illustration 19

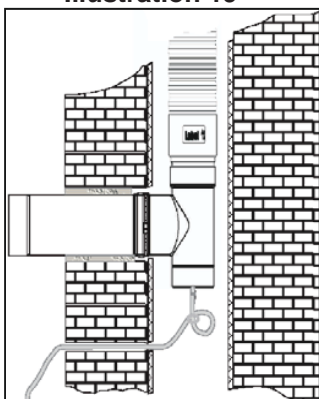

Illustration 20

- Determine if the masonry chimney, factory built chimney or chase can accept the fitting that will connect to the Smoothcore® flex liner by measuring the dimension of the fitting that will be part of the flex liner system. Allow for ½ inch (13mm) more than the dimension of the largest fitting for easy optional installs).
- Connect Smoothcore® flex to the fitting and tighten all connections. (See Illustrations 18-20 or 21-23)
- Tie a guide rope to the flex liner above the male connector so as to prevent the rope from slipping off and lower the rope in the structure to the awaiting person down below.
- Lower the fitting and flex through the chimney top opening while the person below using the guide rope pulls the liner down through to the breaching.

Note: In cases where the structure is unable to accommodate the dimensions of the fitting, the installers may seek an alternate option of attaching the fitting through an enlarged breach accessing the liner from the mechanical room.

- Remove the rope to align the fitting & condensate tube in their final positions. Connect the breach pipe and tighten all connections. Route the tube to a suitable condensate drain or neutralizer.

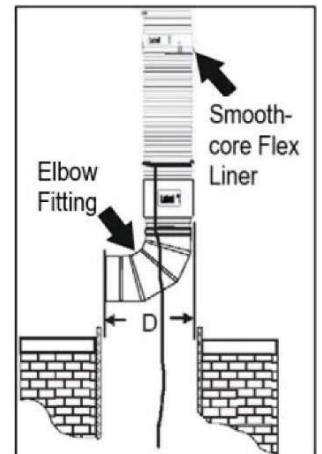

Illustration 21

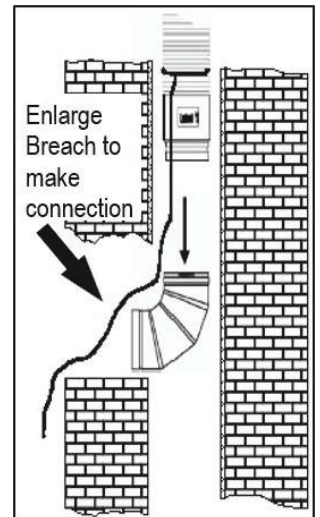

Illustration 22

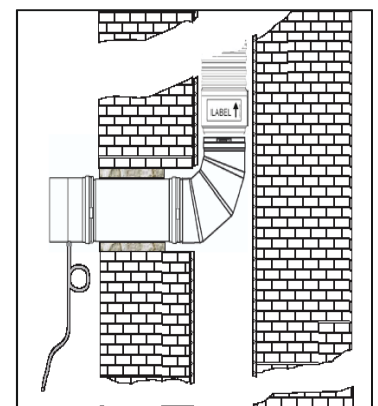

Illustration 23

6. Place the flashing over the liner and position down onto the chimney top and tighten the gear clamp onto the liner.
 - i. Seal and anchor the flashing onto the chimney top using the appropriate materials.
 - ii. Trim the liner just above the flashing collar.
(See Illustration 24)
7. Position the rain cap over the flashing with the gear clamps aligned. Lower the rain cap over the flashing so the gear clamp screw heads of both fittings interlock. Tighten the rain cap gear clamp to lock the entire assembly in position. (See Illustrations 25 & 26)
8. If necessary finish closing off the breach opening using the appropriate materials.
9. Finish connecting the appliance(s) to the Smoothcore® liner by installing the adaptor(s), pipe(s) & fittings to the completed chimney connection.



Illustration 24

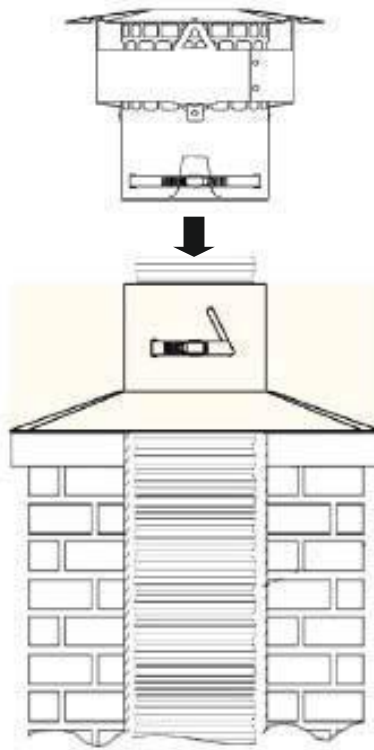

Illustration 25

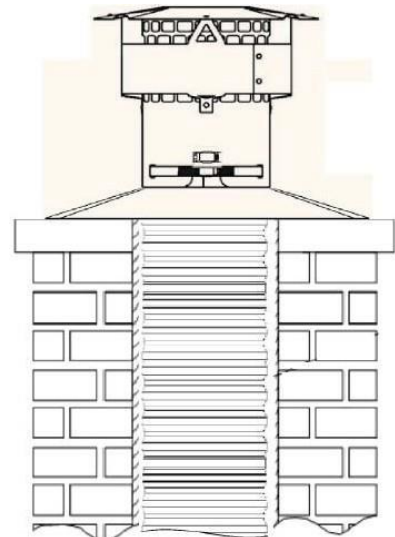

Illustration 26

APPLIANCE CONNECTION

Refer to the appliance manufacturer's installation manual for proper method of joining Z-VENT® to the appliance collar. An appliance adapter to suit specific requirements may be obtained from Z-FLEX®.

IMPORTANT NOTICE

When any of the previous installation procedures are completed, be sure to go over the entire system to make sure all joints are secure and sealed correctly. The seams and joints must be checked for tightness prior to using the venting system. A qualified inspector must check the entire system at least once annually following initial installation to maintain the Z-FLEX® warranty. The installation must conform to the requirements of the appliance manufacturers' instructions, The National Fuel Gas Code and local codes and regulations.

Z-FLEX® LIMITED WARRANTY

Z-FLEX® ("Seller") extends the following LIMITED WARRANTY for
Z-VENT® (the "Z-Vent®"):

Seller warrants that at the time of purchase, the Z-Vent® will be free of manufacturer's defects in material and/or workmanship. This warranty shall extend to the original purchaser of the Z-Vent® or, if purchased by a contractor, to the end user. This warranty is valid for a period of fifteen (15) years from the date of purchase, provided that the Z-Vent® has been installed according to Z-Flex® installation instructions. Deviating from the installation and use instructions included with the Z-Vent® will void the warranty.

Under this Limited Warranty, Seller's sole responsibility and liability shall be to replace the Z-Vent® and/or accessories, if found by Seller to be defective according to the terms of the warranty, and shall not include replacement installation or other costs.

IMPORTANT: The Z-Vent® is designed for use with Category I, II, III and IV furnace and boiler venting and should not be used with any other type of furnace and boiler venting. Use of the Z-Vent® with any other type of furnace and boiler venting other than those recommended by Seller for use with its Z-Vent® will void the warranty.

WARNING: CONDENSATION WITH HIGH ACID CONTENT MAY BE PRODUCED DUE TO UNFORESEEN CONDITIONS. YOUR HEATING APPLIANCE AND VENTING SYSTEM SHOULD BE INSPECTED BY A LICENSED CONTRACTOR ON AN ANNUAL BASIS FOR POSSIBLE SIGNS OF DETERIORATION DUE TO RUSTING OR PIN HOLES. CONDENSATION WITH HIGH ACID CONTENT MAY CAUSE LEAKAGE OF HARMFUL GASES WHICH CAN CAUSE NAUSEA, FAINTING OR DEATH. IF DETERIORATION IS DETECTED CEASE USE OF HEATING SYSTEM AND CALL FURNACE/BOILER INSTALLER FOR REMEDIAL ACTION.

To activate the warranty, the end-user must complete and return the Z-Flex® Warranty Registration Card within ninety (90) days of installation of the Z-Vent®. Upon written notice of any defects, Z-Flex® reserves the right to examine or establish reasonable proof of defective material or workmanship justifying replacement.

NO OTHER EXPRESS WARRANTY HAS BEEN MADE OR WILL BE MADE ON BEHALF OF SELLER WITH RESPECT TO THE Z-VENT® OR THE INSTALLATION OR REPLACEMENT OF THE Z-VENT®. SELLER SHALL NOT BE LIABLE FOR ANY SPECIAL, INCIDENTAL, INDIRECT OR CON-SEQUENTIAL DAMAGES.

As some jurisdictions do not allow the exclusion or limitation of incidental or consequential damages, the above limitations or exclusions may not apply to you.

IMPLIED WARRANTIES, INCLUDING ANY WARRANTY OF MERCHANTABILITY OR FITNESS FOR A PARTICULAR PURPOSE, IMPOSED ON THIS SALE UNDER STATE LAW, ARE LIMITED TO THE PERIOD DURING WHICH THIS WARRANTY IS IN EFFECT. AS SOME JURISDICTIONS DO NOT ALLOW LIMITATIONS ON THE LENGTH OF AN IMPLIED WARRANTY, THE ABOVE LIMITATION MAY NOT APPLY TO YOU.

Claims under this Warranty must be made within the warranty period in writing and directed to: In **the USA**; Warranty Claims, Z-Flex®(US) Inc., 20 Commerce Park North, Bedford, New Hampshire 03110, (603) 669-5136 or (800) 654-5600.

In Canada; Warranty Claims, Z-Flex® Inc., 452 Attwell Drive, Etobicoke, Ontario, M9W 5C3, (416) 679-0045.

This Warranty gives you specific legal rights, and you may also have other rights that vary in different States and Provinces.

WARRANTY REGISTRATION CARD: Z-FLEX®

For this warranty to be effective, this card must be completed upon purchase of the covered Z-Vent® and returned to Z-Flex® within ninety (90) days of installation of the Z-Vent®.

Original end-user's name: _____

Address of premises in which the Z-Vent® is installed: _____

Z-Vent® purchased from: _____

Date of Installation: _____

Type of Heating System into which Z-Vent® installed: _____

I understand and agree to the Warranty as stated: _____

Signature

Date

Z-Vent Instructions July 26, 2022